





OUT

# METER

The E-Meter is a religious artefact intended for use by Scientology ministers, ministers-in-training and other qualified parishioners, as a guide in Confessionals and counselling to help locate the source of spiritual travail. The E-Meter, by itself, does nothing and is neither medically nor scientifically useful for the diagnosis, treatment or prevention of disease.

Ownership of use of the E-Meter by anyone not in good standing with the Church of Scientology is prohibited.

The meter registers before the ‘preclear’ becomes conscious of the datum. It is therefore a “preconscious” meter.

— E-Meter Essentials 1961/2013  
L. Ron Hubbard

# Apocryphal Technologies

Technologies present themselves as the forward image of our desires, and these forward movements often keep us from sensing legitimate disappointment in them. The technological has always promised a great number of apocryphal benefits: from truth telling, to bodily enhancement, to cognitive amplification.

Often things that don't work simply must, as we've invested so much time, effort, emotion, belief and money in them. This rather legitimate disappointment is something we hide from ourselves and each other, making the technologies 'apocryphal': dubiously authentic, reliable, and functionally suspect. All thinking is speculative, and technologies absorb and condense this speculation, in particular as it intersects with 'spiritual' practices.

I would like to employ the word cyber crud to mean, in general, putting things over on people using computers. Cybercrud is one of the most important specialties, if not the economic backbone, of the computer field.

The promotion of false or clumsy approaches to a problem as "scientific," the frequent claim that "the computer has to have it that way"—when a certain thing could be programmed very differently—are cybercrud.

— Theodor H. Nelson  
(Software Exhibition Catalogue 1970 p. 17)

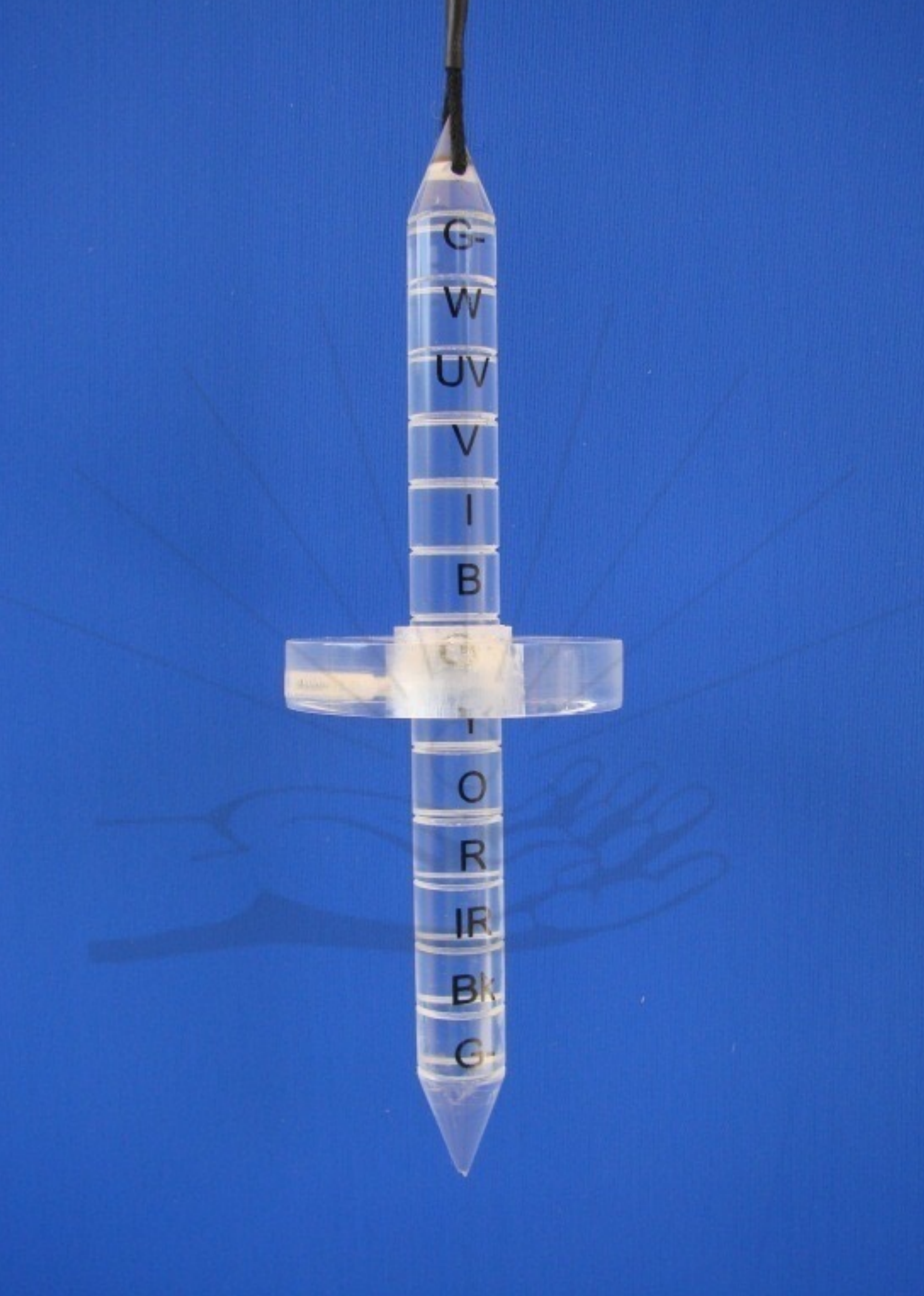

**GUARANTEE 60 DAY SATISFACTION**

**BUTTERFLY ABS**  
WIRELESS & RECHARGEABLE

**AS SEEN ON TV**

**FDA CLEARED TO**

**FIRM, TONE AND STRENGTHEN YOUR ABS AUTOMATICALLY!**

**NOW ONLY \$39.99**  
+\$9.95 P&H

**YOUR COMPLETE BUTTERFLY ABS SYSTEM INCLUDES:**

- Rechargeable EMS unit
- 2 Reusable Toning Pads
- USB charger

**FREE BONUSES!**

- 2 Additional Toning Pads
- Workout Guide

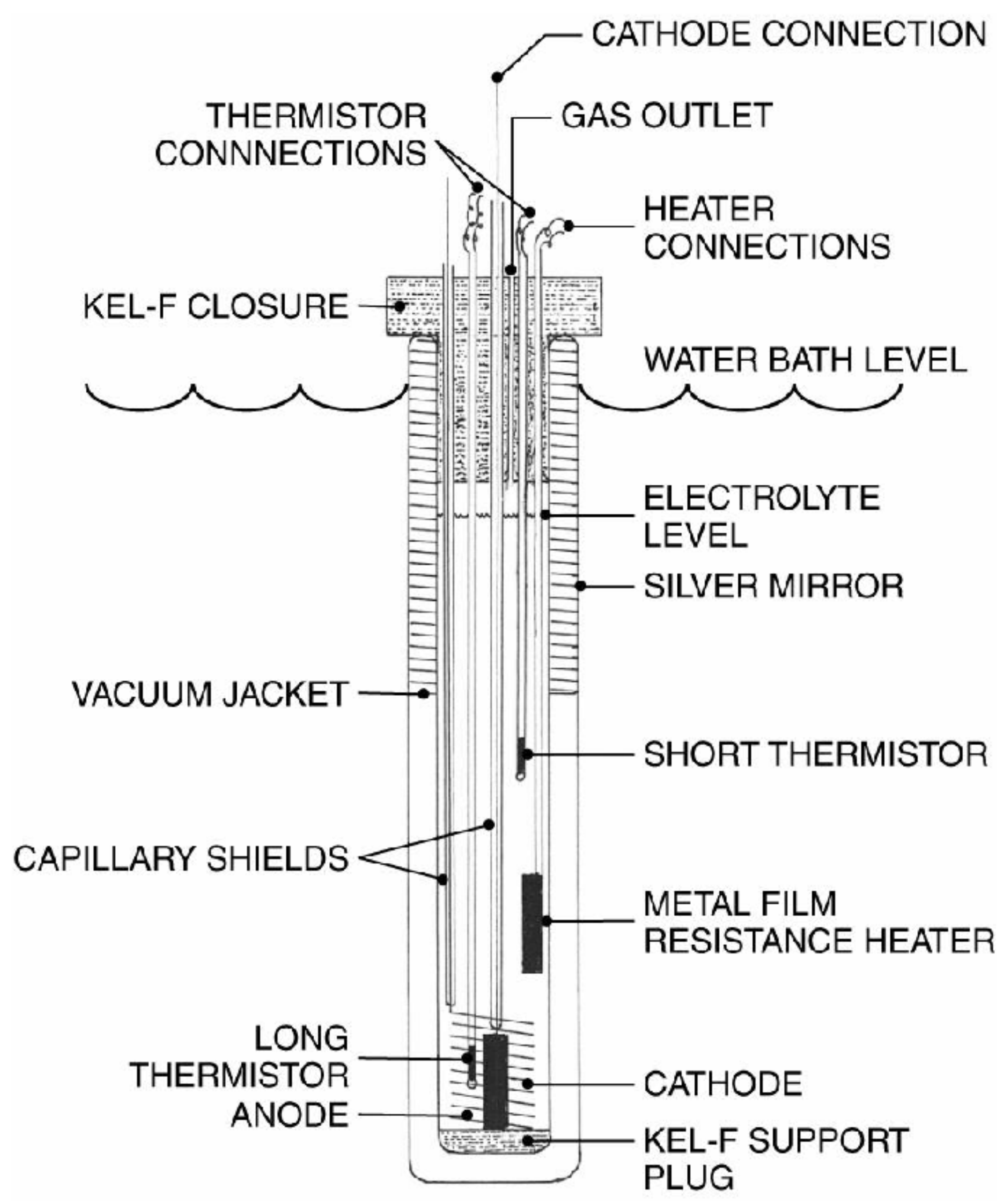
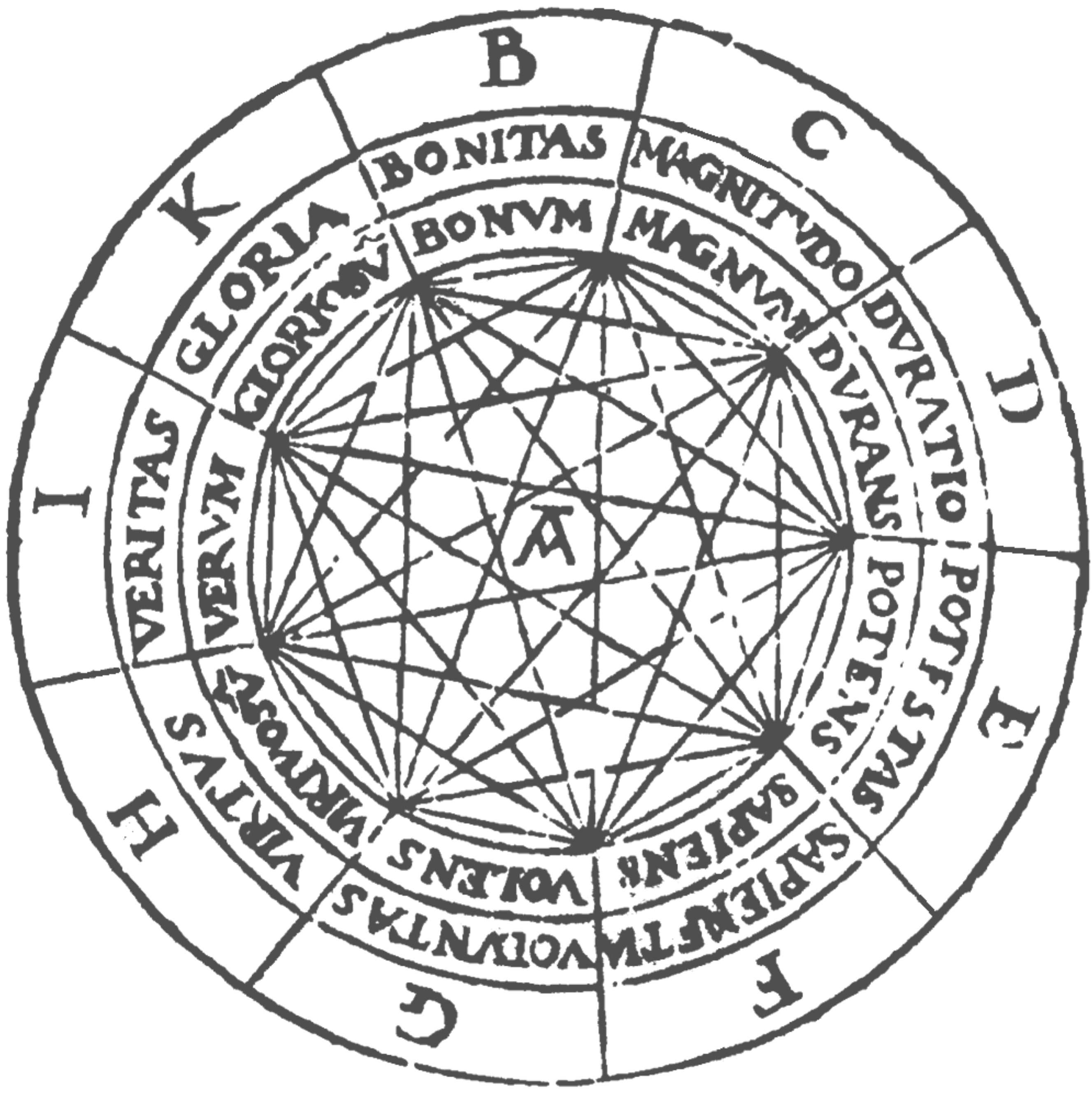

**YES OUIJA**  
MYSTIFYING ORACLE

**NO**

**ABCDEFGHIJKLM**

**NOPQRSTUVWXYZ**

**1234567890**

**GOOD BYE**





# The Long Cybernetic Century

There are many ways of describing what cybernetics was. The most insightful for present purposes follows the conception of one of the leading English cyberneticians, Stafford Beer. Beer's basic starting point was explicitly ontological.

He insisted that the world was what he called 'an exceedingly complex system' (Beer 1959)—one which was impossible to know and control fully. So cybernetics began from de Kooning rather than Mondrian, acknowledging from the start that human detachment from and domination of the world is, at best, a fallible strategy. What was left for cybernetics, then, was a kind of engineering in the thick of things—the development of technologies that would be light on their feet, a form of adaptive engineering based upon open-ended forward looking searches through spaces of possibility that could not be exhaustively foreseen in advance.

Cybernetics' distinctive ontology fed into distinctive approaches in areas of human endeavour as various as brain science and artificial intelligence, robotics, information theory and theoretical biology, on the one side, and psychiatry, management, politics, the arts and spirituality on the other. Cybernetics thus showed that bringing to consciousness a decentred and temporalised ontology can make a big difference in the world, restructuring and reconfiguring great swathes of culture and practice—it was a nomad science.

— Andrew Pickering  
New Ontologies 2006



**ACTUALITÉS SCIENTIFIQUES ET INDUSTRIELLES**

**1053**

# **CYBERNETICS**

**OR**

**CONTROL AND COMMUNICATION  
IN THE ANIMAL AND THE MACHINE**

**BY**

**NORBERT WIENER**

Professor of Mathematics at the Massachusetts Institute  
of Technology  
Guest Investigator at the Instituto Nacional de Cardiología  
de México.



**PARIS**

**HERMANN & C<sup>ie</sup>, ÉDITEURS**

6, Rue de la Sorbonne, 6

**THE TECHNOLOGY PRESS**

Cambridge, Mass.

**JOHN WILEY & Sons. Inc.**

440 Fourth Av., New York

**1948**

DIRECTOR, A.A., M7\*, M7A1B1\*\*, M7A1B2\*  
 (\*\*standard, \*substitute standard)

DIRECTOR M7 OR M7A1B1  
 LEFT SIDE

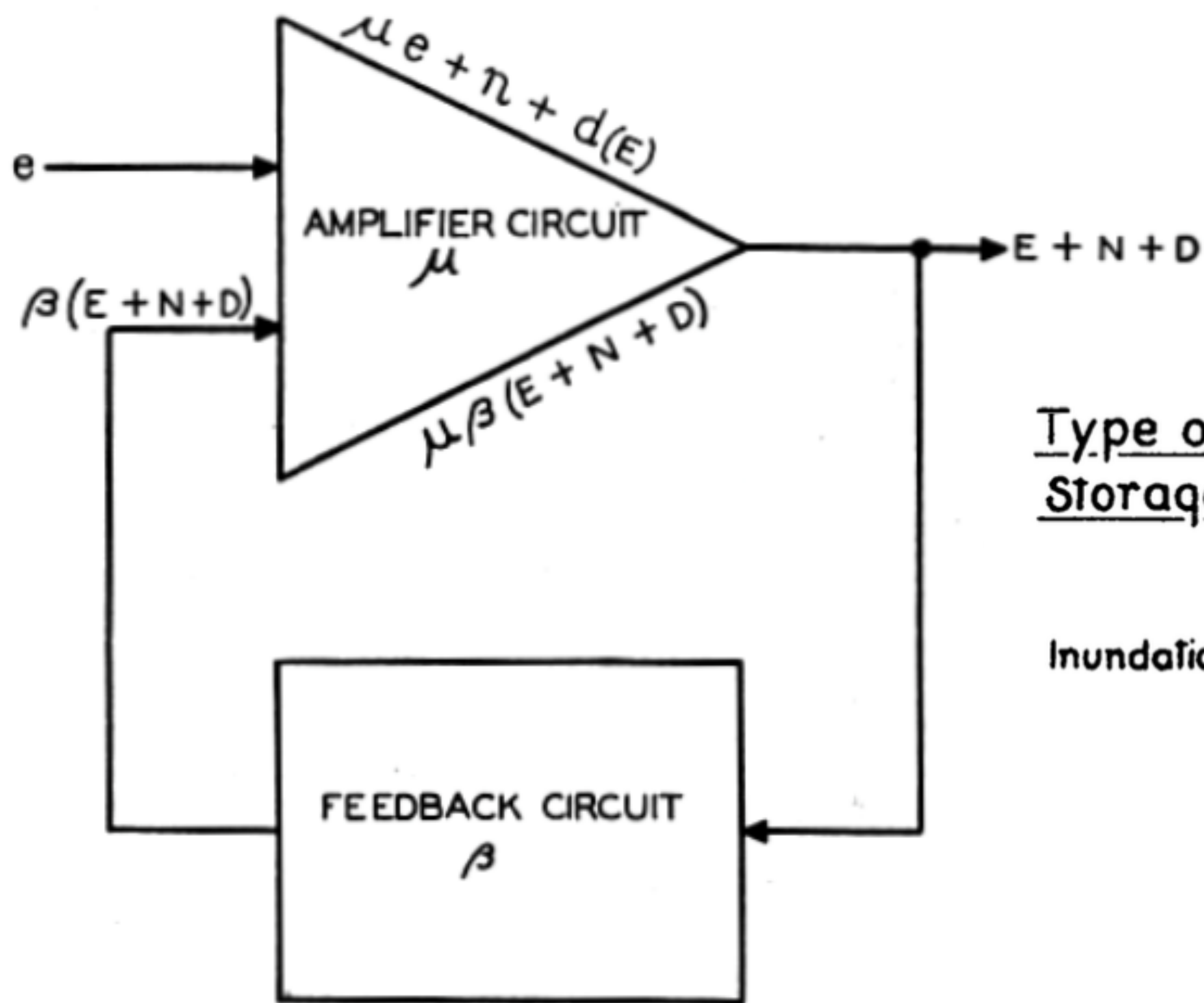
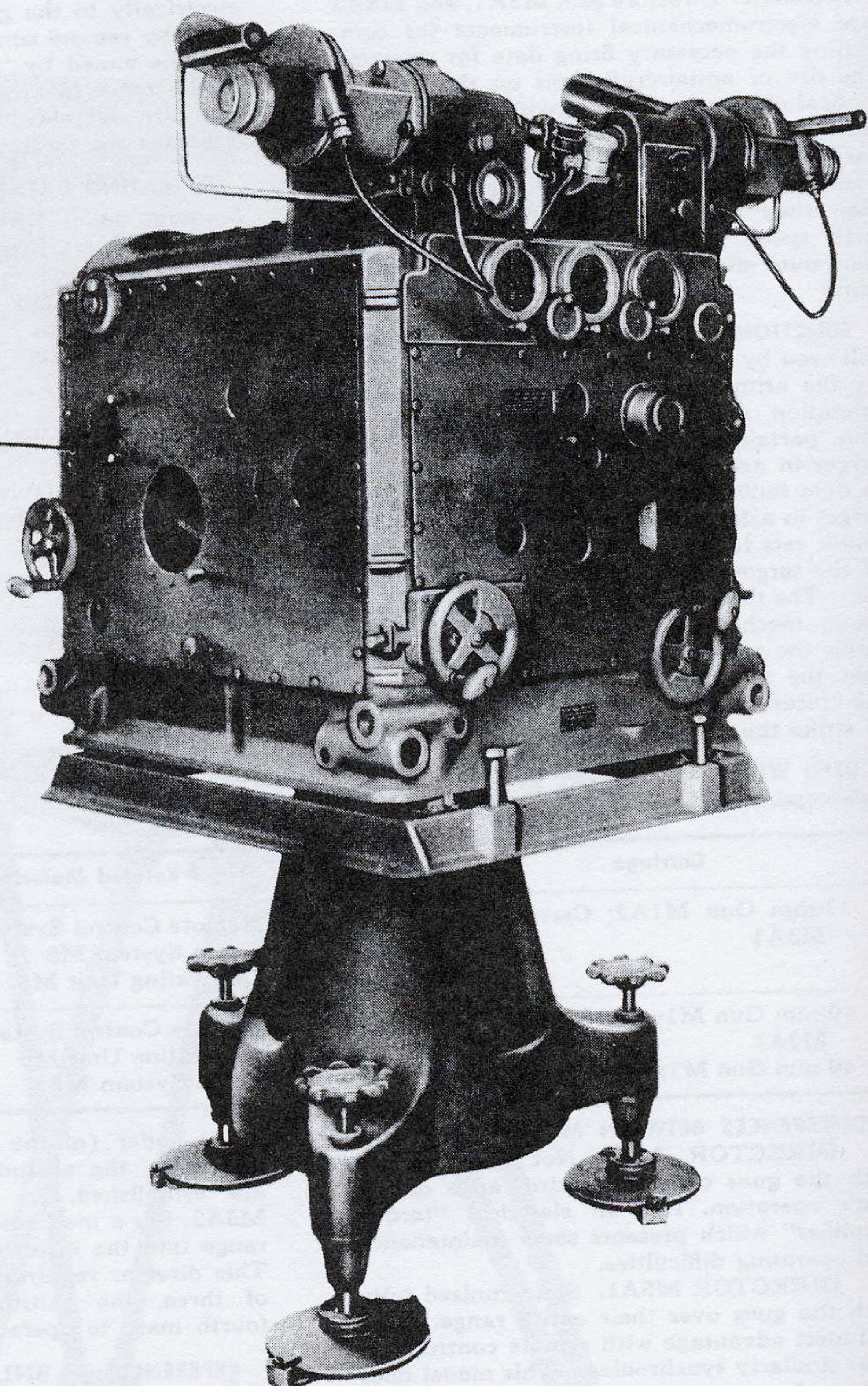

Type of Storage

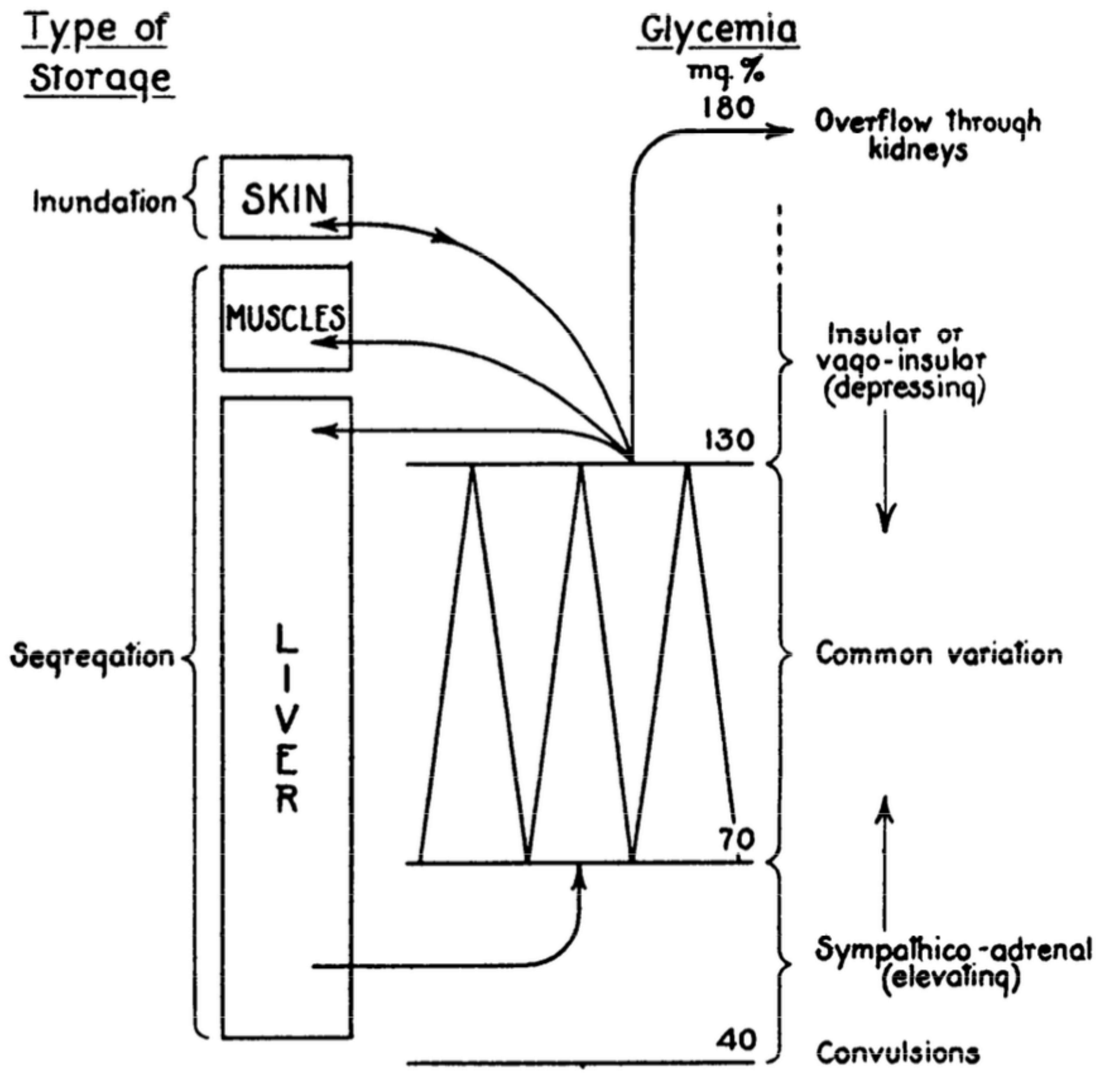

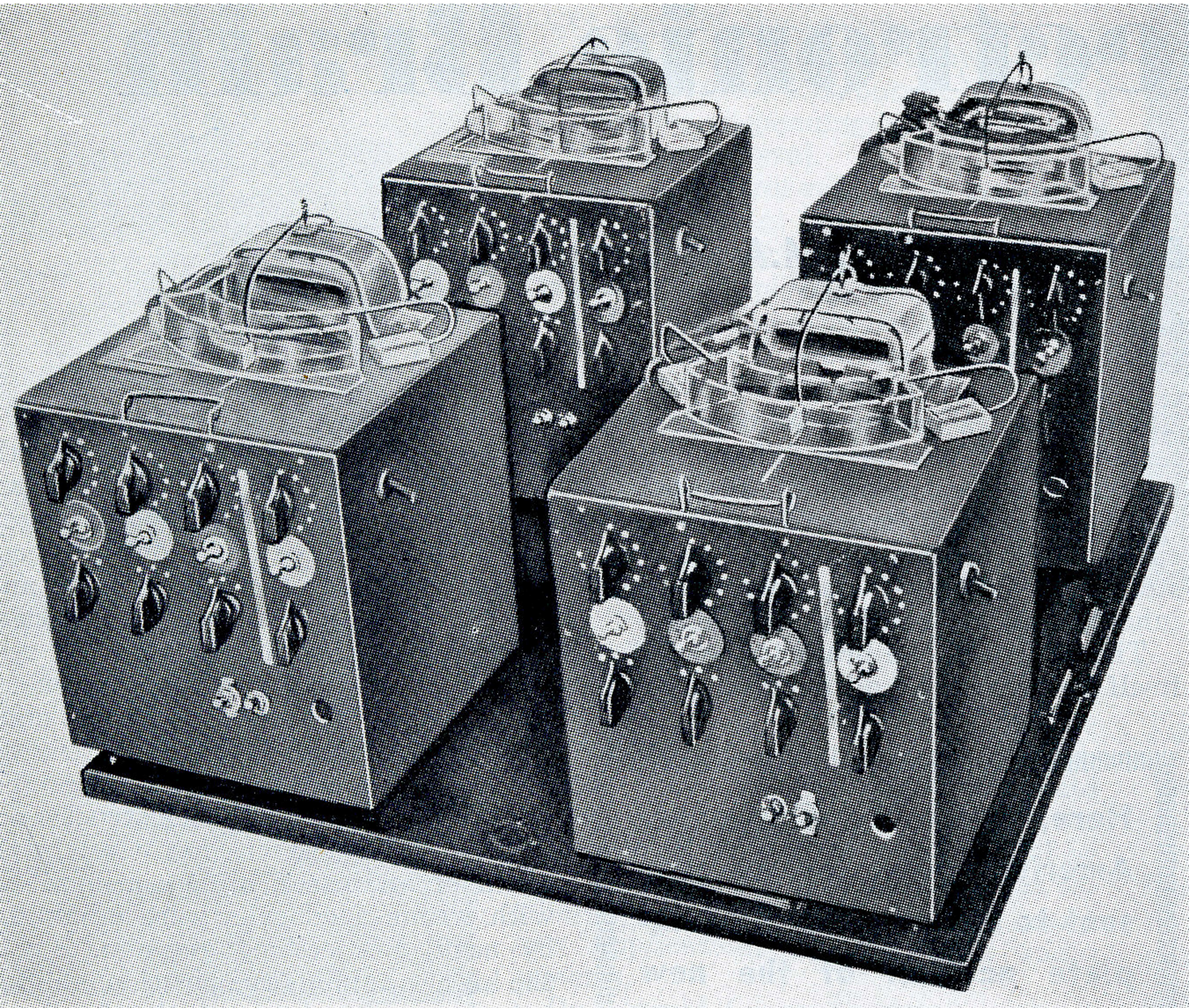
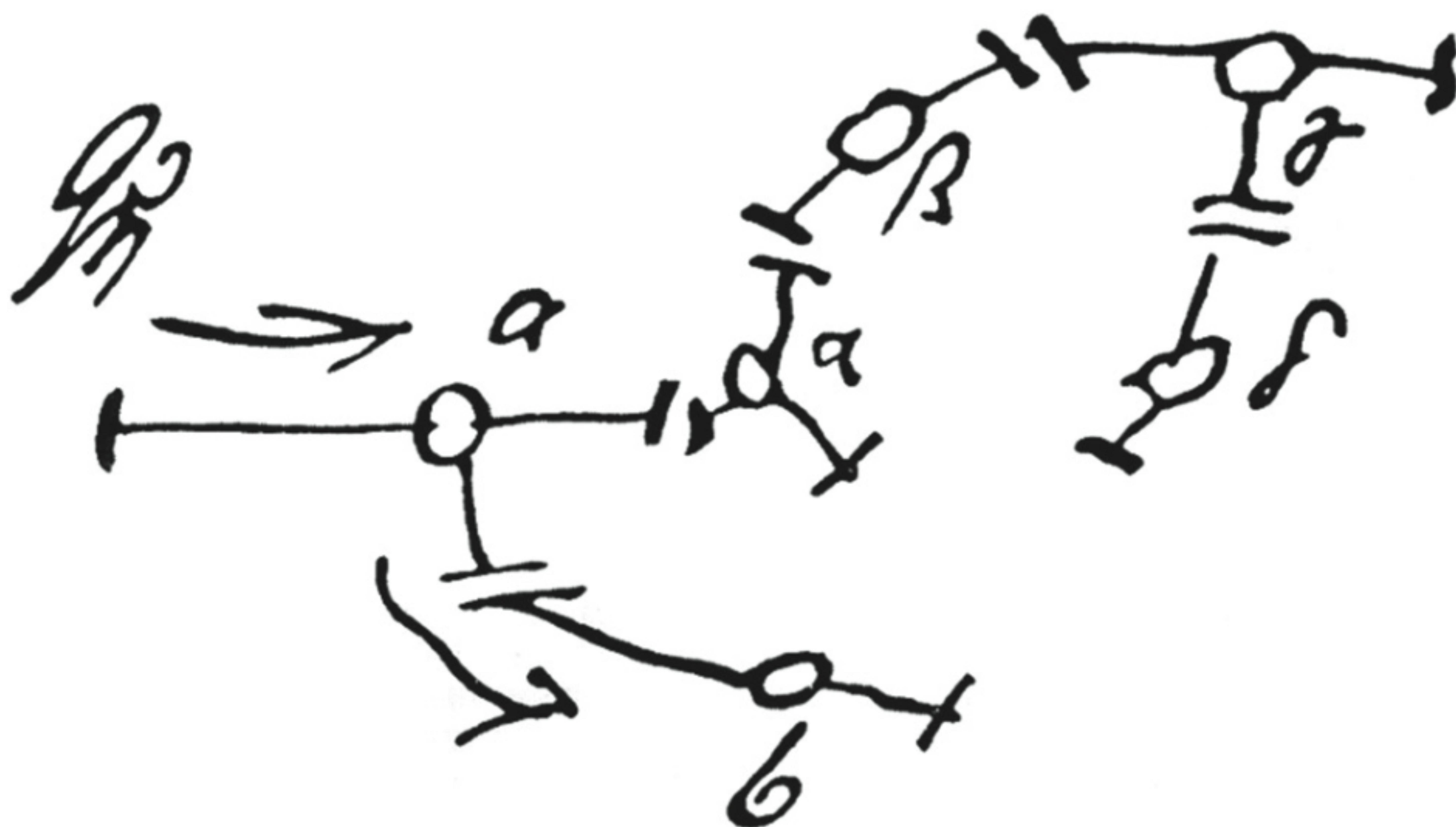
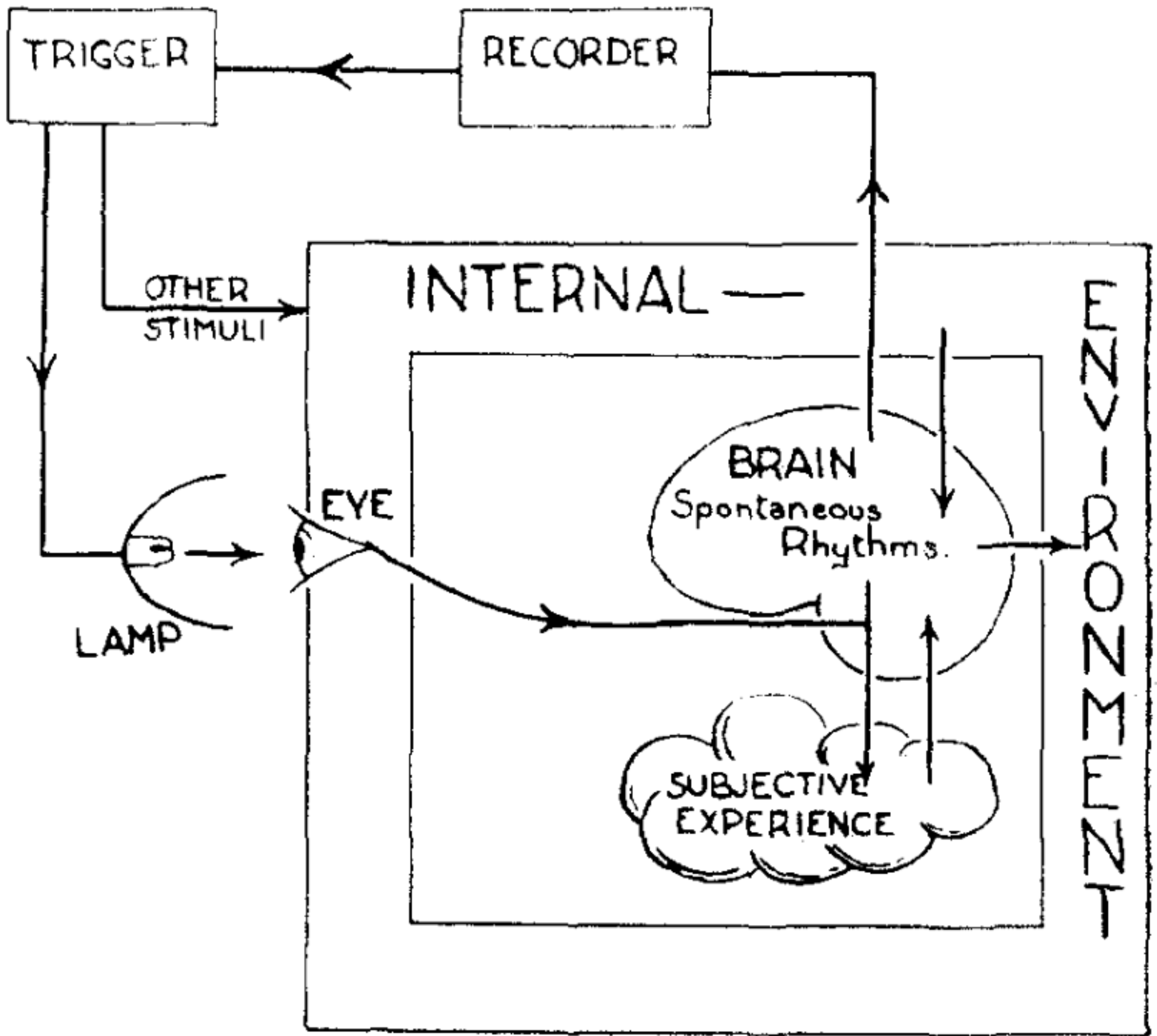
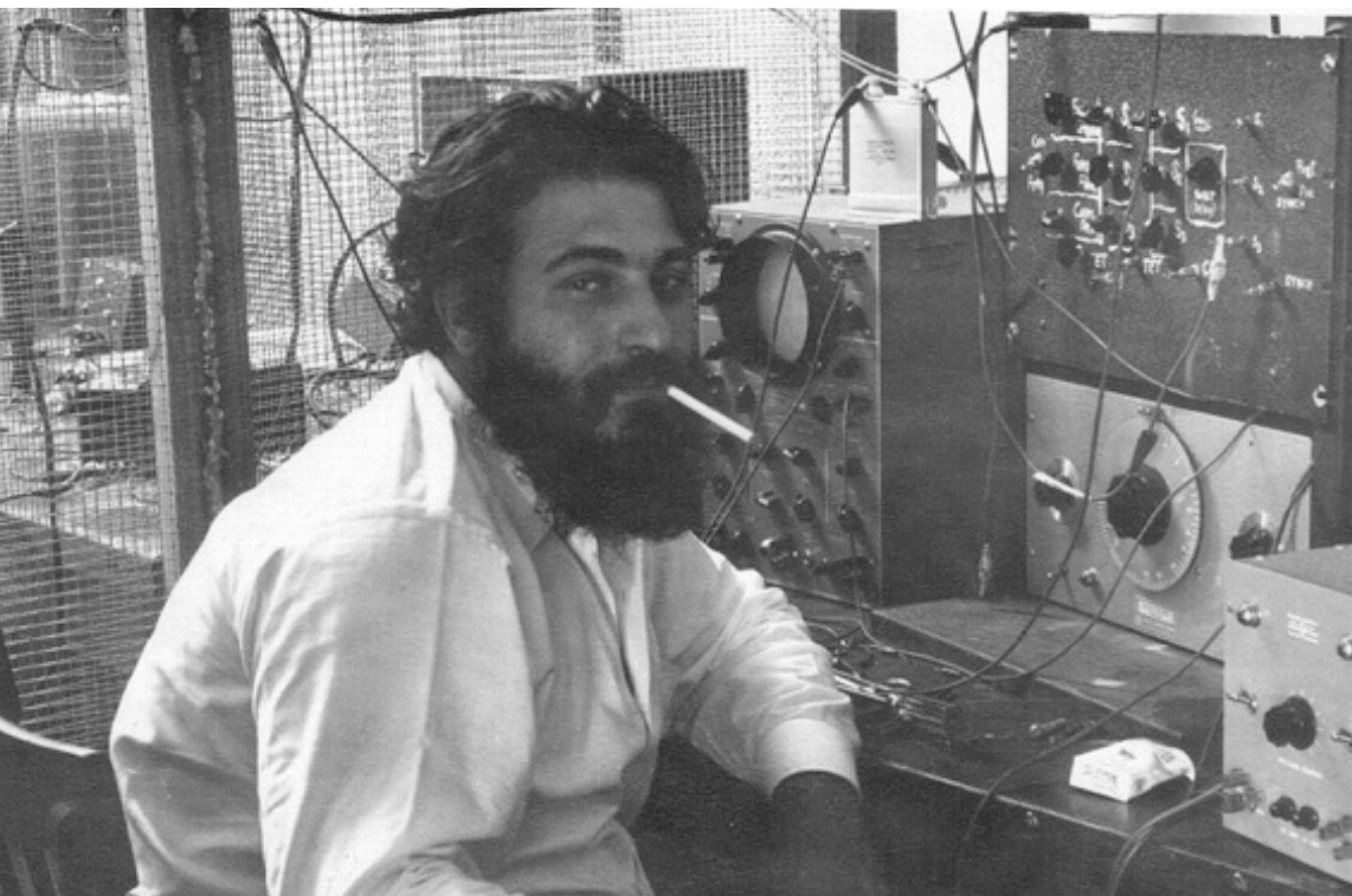
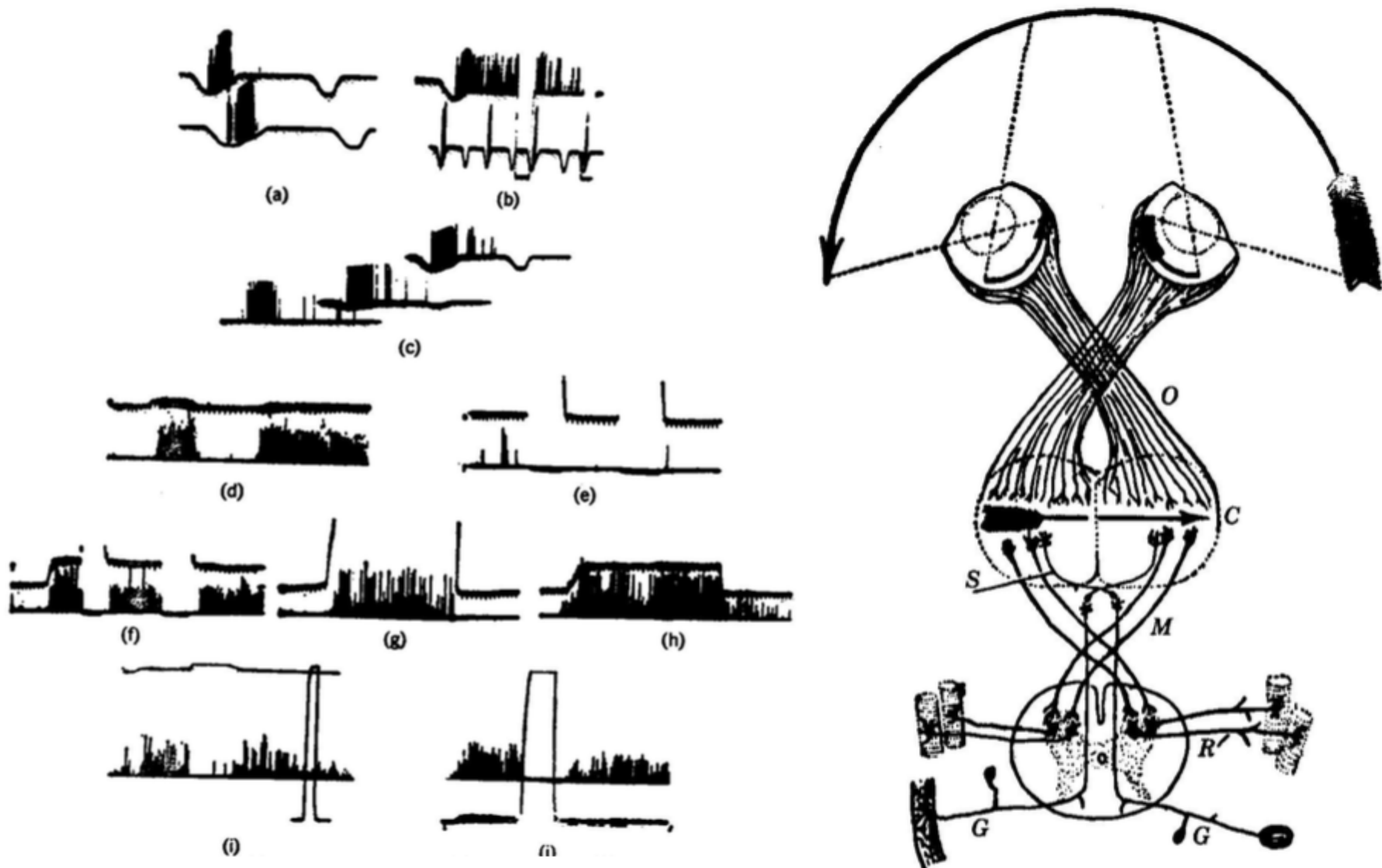

Fig. 1—The homeostat, with its four units, each one of which reacts on all the others.



Freud's (1950 [1895]) own sketch of neurons and the flow of neural energy, illustrating his concept of diversion of neural energy via a "side-cathexis." The normal flow of energy (arrow on left labeled  $Q'\eta$ ) is from neuron "a" to "b." Freud proposed that a side-cathexis of neuron " $\alpha$ " would attract the  $Q'\eta$  and divert the flow from neuron "b." He believed this postsynaptic attraction of energy or side-cathexis was the neuronal mechanism underlying repression of forbidden wishes in both waking and dreaming (from McCarley, 1998).





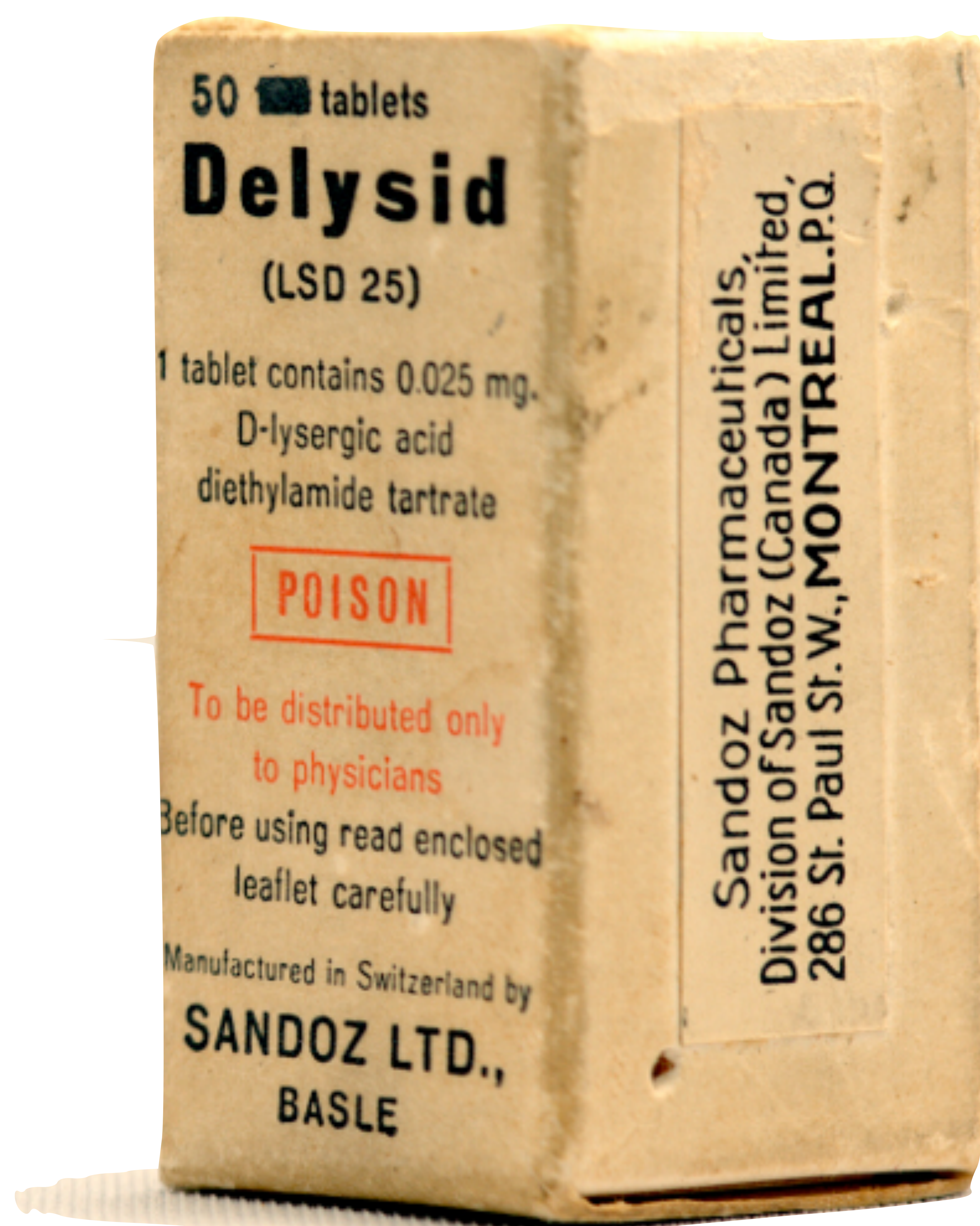

# WHOLE EARTH CATALOG

*access to tools*



Fall 1968

\$5

## The Human Use of Human Beings

Whole Systems 11

*Norbert Wiener is one of the founders of an n-dimensional inhabited world whose nature we've yet to learn. He is also one of the all-time nice men.*

*A proper sequel to his Cybernetics (see p. 32), this book is social, untechnical, ultimate in most of its consideration. Its domain is the whole earth of the mind.*

### *The Human Use of Human Beings*

Norbert Wiener  
1950, 1954; 288pp

**\$1.25**

From  
Anchor Books  
250 West 55th Street  
New York, N.Y. 10019

or any good book stores





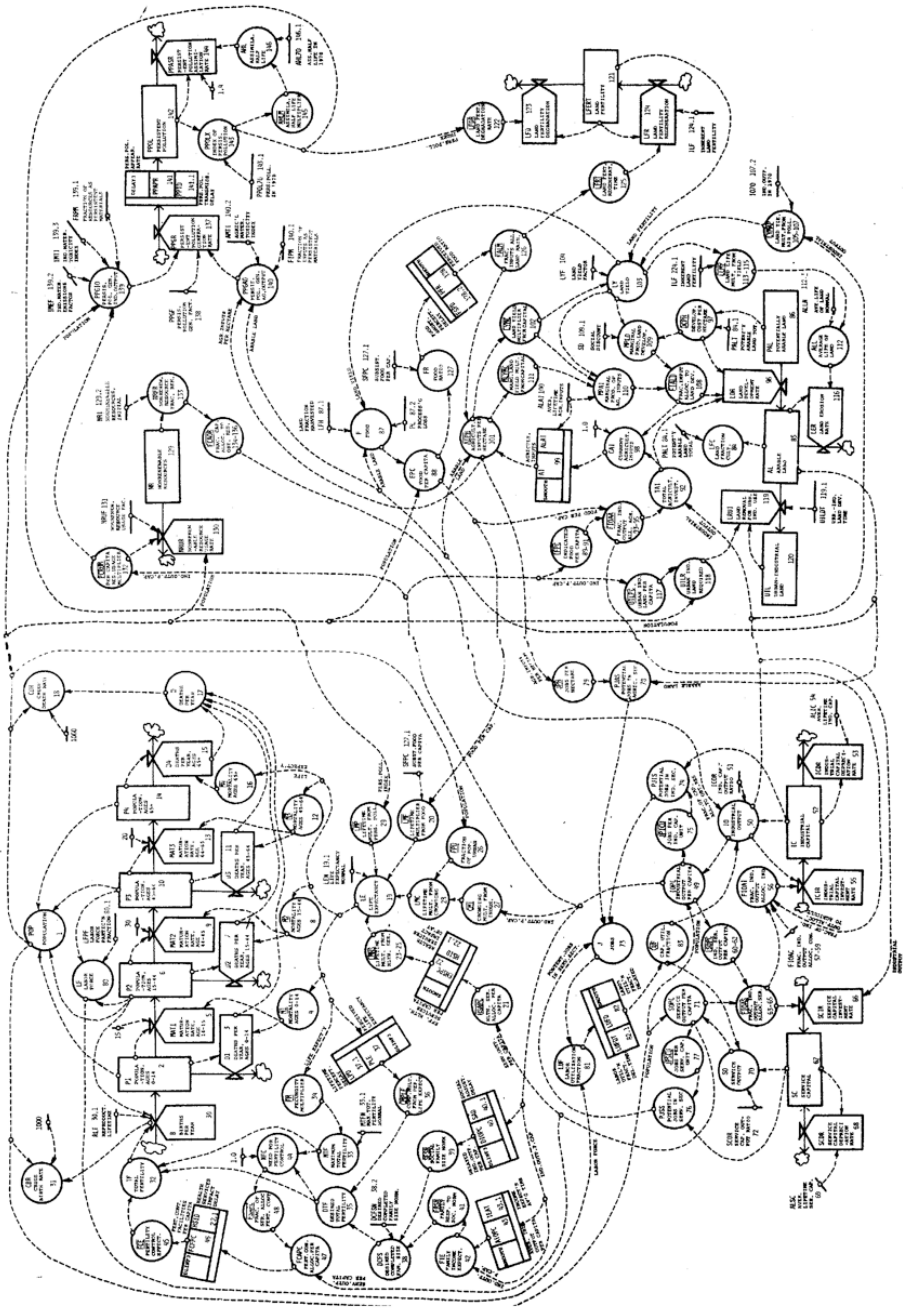

# ARPANET LOGICAL MAP, MARCH 1977

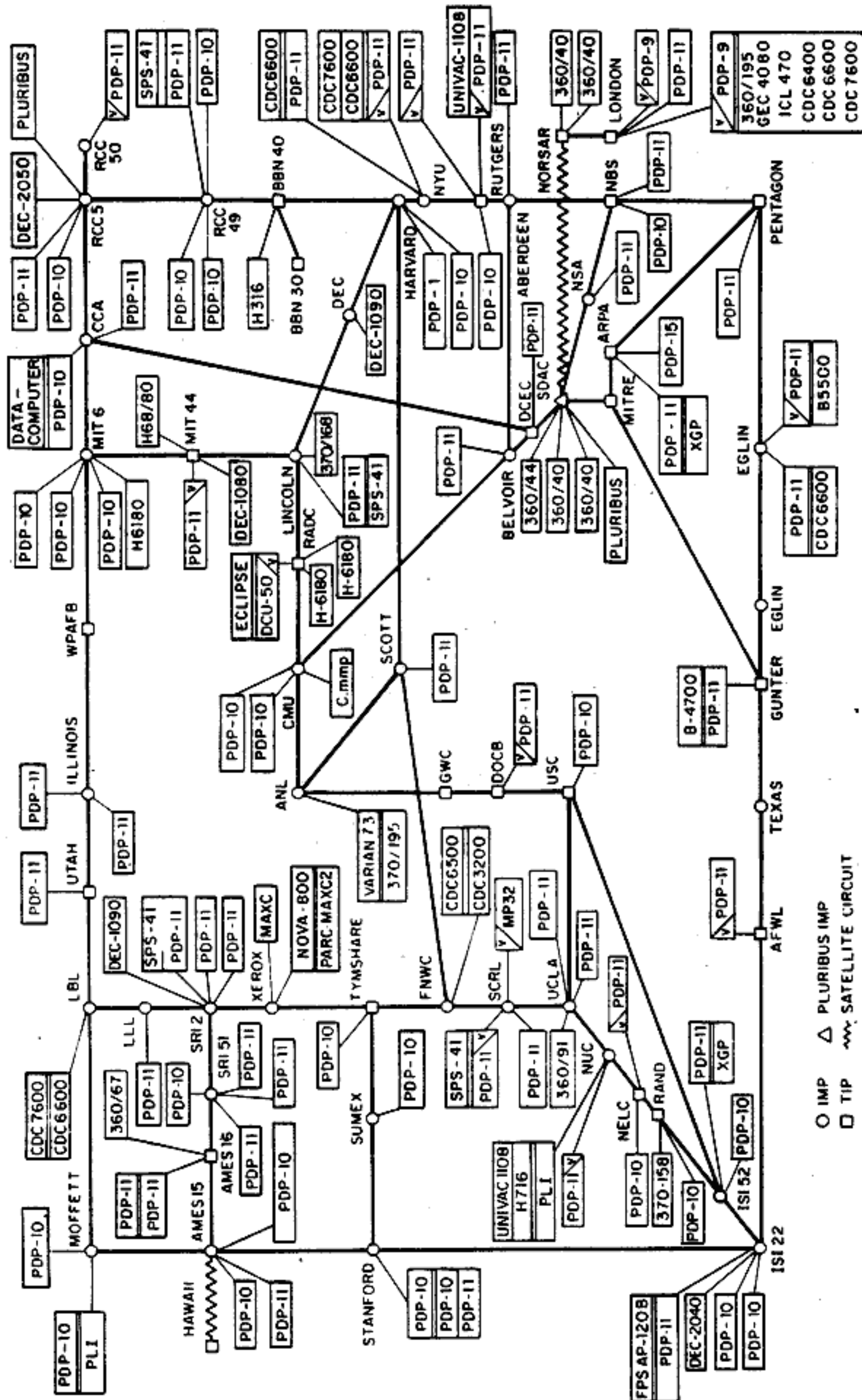

(PLEASE NOTE THAT WHILE THIS MAP SHOWS THE HOST POPULATION OF THE NETWORK ACCORDING TO THE BEST INFORMATION OBTAINABLE, NO CLAIM CAN BE MADE FOR ITS ACCURACY)

NAMES SHOWN ARE IMP NAMES, NOT (NECESSARILY) HOST NAMES

# Measuring the Body

I took a piece of paper, I shaped it into a very tight roll, one end of which I applied to the precordial region and putting the ear to the other end, I was as much surprised as satisfied to hear the heart beats in a manner much more clearly and distinctly than I had by immediate application of the ear... From that moment on, I presumed that this medium could become a utile method, and applicable not only to the study of the heart beats, but furthermore to the study of all the movements that can produce noise in the thoracic cavity, and consequently to the exploration of breathing, of voice, of rattle and perhaps even of the fluctuation of a liquid poured out in the pleurae or the pericardia.

— René Laënnec

De l'auscultation médiate ou traité du diagnostic des maladies de  
poumons et du coeur, fondé principalement sur ce nouveau moyen  
d'exploration 1819

In order to hear [the message], [the doctor] must eliminate the noise (il faut qu'il élimine le bruit) and shut the ears (qu'il se bouche les oreilles) from everything that is not an element of the message.

In his first version of the Panopticon, Bentham had also imagined an acoustic surveillance, operated by means of pipes leading from the cells to the central tower. In the Postscript he abandons the idea, perhaps because he could not introduce into it the principle of dissymmetry and prevent the prisoners from hearing the inspector as well as the inspector hearing them.

— Michel Foucault

Message ou Bruit 1966  
Discipline and Punish 1975

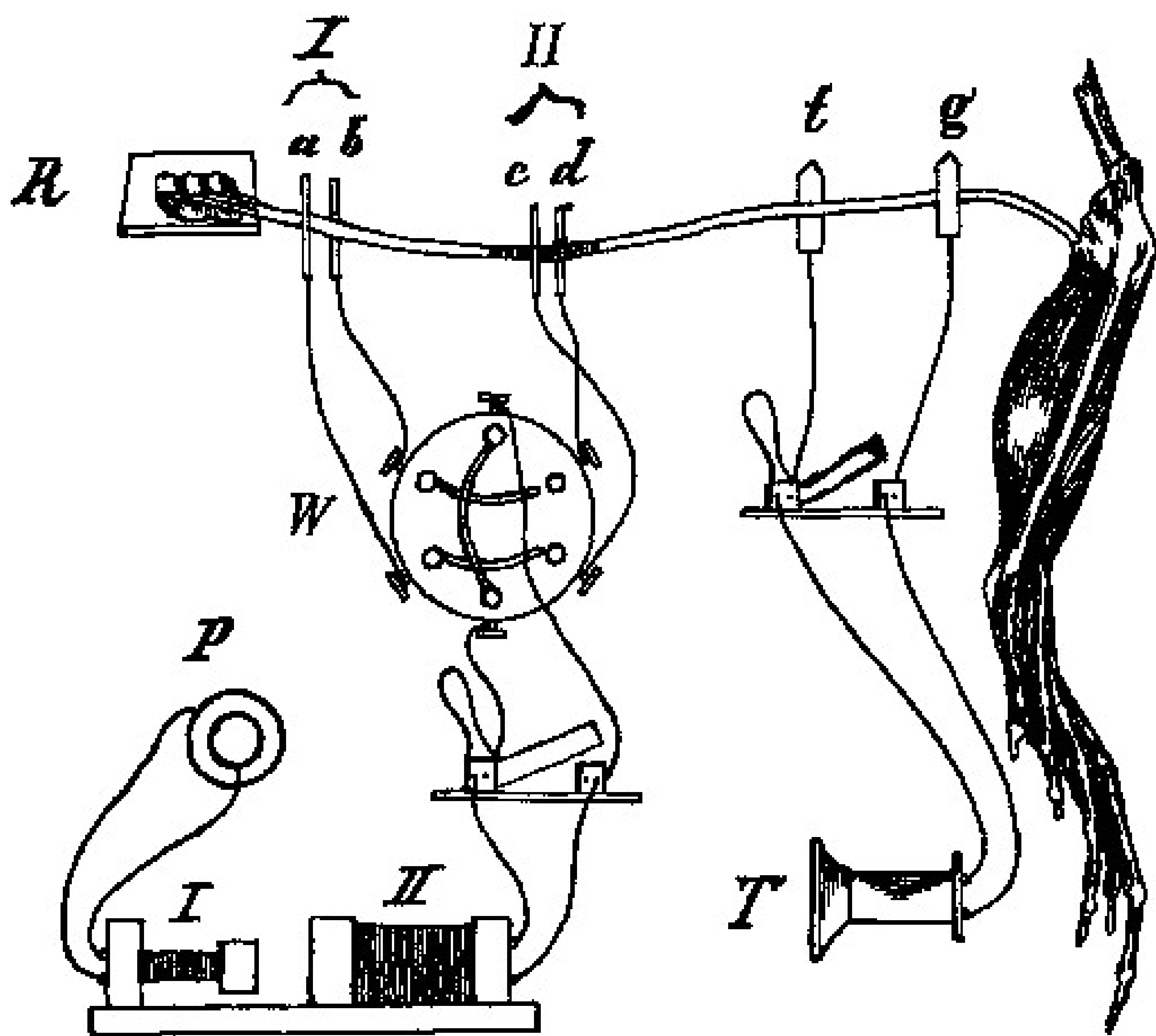



**E**  
**F P**  
**T O Z**  
**L P E D**  
**P E C F D**  
**E D F C Z P**  
**F E L O P Z D**  
**D E F P O T E C**  
**L E F O D P C T**  
**F D F L T C E O**  
**F E R O L C F T D**

- 1 20/200
- 2 20/100
- 3 20/70
- 4 20/50
- 5 20/40
- 6 20/30
- 7 20/25
- 8 20/20
- 9
- 10
- 11





# Images Custom

Chest



Barbell Front Raise and Pullover    Barbell Neck Press    Bench Press



Bench Press Dumbbell    Bent Arm Pullover    Bosu Ball Push Up



# Bench Press

Chest

🕒 59    🕒 90    🕒 120

Weight: 225    Reps: 8    ✓

Tap here to add note

Record 225 x 8 reps 1RM 279 yesterday

1 5:44 PM 185 x 5 reps 1RM 208

## 10/17/2014

1 9:43 AM 185 x 5 reps 1RM 208

Warm up

2 9:44 AM 🏆 225 x 8 reps 1RM 279

3 9:46 AM 205 x 8 reps 1RM 255

Help on last set

## 10/10/2014

1 12:48 PM 185 x 6 reps 1RM 215

2 12:51 PM 225 x 6 reps 1RM 261

# 10/6/2014

Monday, 10:12 AM - 11:17 AM (01:05)

## Upper Body

11 Sets

105 Repetitions / Volume 13985

3 Records

Gold's Gym Atlanta. Well rested after 9 hours sleep, pre-workout carbohydrate nutrition.

## Bench Press

1 10:12 AM 180 x 11 reps 1RM 245

2 10:14 AM 🏆 195 x 11 reps 1RM 266

3 10:17 AM 205 x 5 reps 1RM 231

## Dumbbell Flys

1 10:25 AM 40 x 8 reps 1RM 50

2 10:30 AM 🏆 45 x 12 reps 1RM 63

3 10:34 AM 35 x 8 reps 1RM 43

## Overhand Pull Downs





# Cybernetic Scientology: The E-Meter

Electrodermal activity (EDA), is the property of the human body that causes continuous variation in the electrical characteristics of the skin. Historically, EDA has also been known as skin conductance, galvanic skin response (GSR), electrodermal response (EDR), psychogalvanic reflex (PGR), skin conductance response (SCR), and skin conductance level (SCL). The long history of research into the active and passive electrical properties of the skin by a variety of disciplines has resulted in an excess of names, now standardized to electrodermal activity (EDA).

The E-meter used by the Church of Scientology as part of its practice of "auditing" and "security checking", is a custom EDA measurement device.[26]

—Electrodermal activity (wikipedia)

The leadership membership of Scientology™ has, since their inception as an organised religion, concretised a set of apocryphal spiritual practices around a technology called the “E-Meter.”



# Schweizerische Blätter

für

# ELEKTROTECHNIK

## und das gesamte Beleuchtungswesen

mit Beiblatt

„Technischer Arbeitsmarkt“

Organ f. Arbeitsvermittlung sämtlicher technischer Branchen.

2 Mal monatlich.

Abonnement: { Schweiz Fr. 6.—  
Ausland „ 8.—

Insertionspreis:  
Die viergespaltene Petitzeile oder deren Raum 25 Cts. — 20 Pf. — 25 H.  
Grössere Aufträge erhalten entsprechenden Rabatt. Berechnungen kundentreu.

Verantwortliche Redaktion: Hermann A. Messer.

Administration u. Annoncenregie: Sutermeister & Messer, Polytechn. Verlags-Institut, Limmatquai 22, Zürich.



### Inhaltsverzeichnis.

Das elektrische Leitvermögen des menschlichen Körpers als Masstab für seine Nervosität (nervöse Erregbarkeit). — Herstellung von galvanischen Metall-Niederschlägen. — Kleine Mitteilungen. — Schweizerische Rundschau. — Ausländische Rundschau. — Submissionen. — Auszug aus der schweizer. Patentliste.

### Das elektrische Leitvermögen des menschlichen Körpers als Masstab für seine Nervosität (nervöse Erregbarkeit).

Während Versuche über das elektrische Leitvermögen anorganischer oder doch wenigstens nicht organisierter Körper von jeher in grosser Anzahl ausgeführt wurden, sind Untersuchungen, welche sich mit der elektrischen Leitfähigkeit des Organismus (Pflanze oder Tier) beschäftigen, nur in relativ geringer Anzahl ausgeführt worden.

Wenn auch, wie aus der Literatur hervorgeht, früher bekannte Autoritäten diese Verhältnisse am tierischen Körper im normalen und pathologischen Zustande

**Eugen Konrad Müller — 1904**

Das elektrische Leitvermögen des menschlichen Körpers als Masstab für seine Nervosität. (Electric conductance of the human body as a measure for his nervousness.)

Dennoch schenkte man dieser Betrachtung gewisser seltsamer Erscheinungen, welche ich zu beobachten Gelegenheit hatte, die Wahrscheinlichkeit sehr nahe liegend, dass die Beobachtung und Kontrolle der elektrischen

Leitfähigkeit des menschlichen Körpers durch physikalische Mittel, wie sie im Prinzip bei den Widerstandsbestimmungen zur Verwendung gelangen, sich als subtiles und wichtiges Hilfsmittel zu physiologischen Untersuchungen, sowie diagnostischen und therapeutischen Zwecken erweisen dürften und zwar auch ganz im Sinne jener wertvollen Eigenschaften der Widerstandsbestimmungen, über physikalische und chemische Vorgänge im Körperinnern und über die Natur der Veränderungen jederzeit Aufschluss zu geben, im Sinne einer Sonde, welche ermöglicht, Beschaffenheit und Zustände subjektiver Art, objektiv zu verfolgen.

Bei Anlass einer Untersuchung, es handelte sich um die Nachprüfung der Beobachtung direkt nachweisbarer auffallender Einflüsse des magnetischen Wechselfeldes auf das Leitvermögen des menschlichen Körpers, hatte ich Gelegenheit wahrzunehmen, welche ausserordentliche Variabilität die Ergebnisse der Widerstandsmessungen am menschlichen Organismus aufweisen. Experimentelle Untersuchungen, bei welchen ich selbst Versuchsperson und messender Beobachter zugleich war,

Die Ergebnisse, die ich vermuten liess, es stehe diese Variabilität in grosser Beziehung zum psychischen, resp. psychoneurotischen Zustand der Versuchsperson.

Das Bestehen eines direkten oder indirekten Einflusses der Tätigkeit des Nervensystems auf die Messungsergebnisse erschien mir unbedeutend und mit aller Mühe in dieser Richtung Aufschluss zu geben. Zu diesem Zweck wurden mehrere Personen, welche das Wesen der Untersuchung besaßen, während mehrerer Wochen täglich öfters der elektrische Widerstand bestimmt. Aus dem gewonnenen grossen Zahlenmaterial der Untersuchung geht vorderhand Folgendes mit Sicherheit hervor.

curves, which place before our eyes the strong feeling-tone in a specially clear manner. The following is such an example :

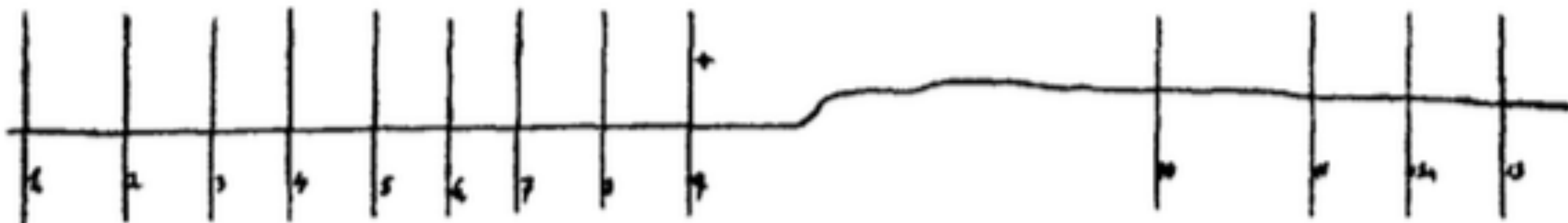

Figure II.

In the beginning we see the curve taking its way horizontally, without any irregularity. In this phase are the following eight reactions :

- |            |       |          |         |
|------------|-------|----------|---------|
| 1. Hot     | Cold  | 5. Mouth | Teeth   |
| 2. Hand    | Foot  | 6. Wake  | Wake up |
| 3. Apple   | Fruit | 7. Drink | Eat     |
| 4. Naughty | Angry | 8. Bed   | Sleep   |

These reactions do not show anything of interest ; their

**Carl Jung — 1907**

*Psychic Influences on the Galvanometer.*

As soon as the test person is placed in the circuit and the experiment begins there is a rapid rise in the curve with some fluctuation, which we find due to expectant attention, a form of emotion. The extent of this expectation curve varies in different individuals, depending upon the degree of affectivity. In beginning an experiment, therefore, we waited until the effects of expectation had subsided and the galvanometer was stationary.

We employed first the following series of varied stimuli: sensory, verbal, strong, indifferent, intellectual, and emotional. Frequently the test person was in an adjoining room, at some distance from the recording apparatus, for electrical and signalling connexions for almost any distance can be readily adjusted.

1. A loud whistle.
2. Fall of a heavy weight with loud noise.
3. Multiply  $4 \times 5$ .
4. Multiply  $9 \times 11$ .
5. Multiply  $8 \times 12$ .
6. Sudden call of test person by name.
7. Where do you live?
8. What is the capital of Switzerland?
9. What is the capital of France?
10. How old are you?
11. Are you married?
12. Were you engaged once, before?
13. Have you been long at your present employment?
14. Threat with prick of needle after counting 1, 2, 3.
15. Threat of letting fall a heavy weight after counting 1, 2, 3.
16. What is your first name?
17. What is the first name of your wife?
18. Is she pretty?
19. We have now finished.

Peterson — 1907

The Galvanometer As A Measurer Of Emotions

# ELEKTROBIOLOGIE

DIE LEHRE VON DEN  
ELEKTRISCHEN VORGÄNGEN IM ORGANISMUS  
AUF MODERNER GRUNDLAGE DARGESTELLT

VON

JULIUS BERNSTEIN

O. Ö. PROFESSOR DER PHYSIOLOGIE AN DER UNIVERSITÄT

HALLE A. S.

---

MIT 62 ABBILDUNGEN IM TEXT



BRAUNSCHWEIG

DRUCK UND VERLAG VON FRIEDR. VIEWEG & SOHN

1912

## CHAPTER VIII

### GENESIS OF THE ELECTROPSYCHOMETER

In 1950 I obtained patents on what promised to be a valuable invention--a device to be used in motion-picture theaters to analyze continuously by electronic means the mixture of light frequencies in projection arc lamps, and thereby, through a warning buzzer signal, to enable the motion-picture projectionist to avoid the muddy, brown, or other off-color effects often noted on the motion-picture screen.

Many hundreds of these machines were ordered--then television swept upon the movie field like a hurricane. Business vanished. Orders for the "Arcon Monitor" were cancelled wholesale.

In a very upset state, I went to a psychoanalyst, seeking relief from nervous tensions. Not getting satisfactory results, I next attended a series of lectures being given by a very controversial figure, who several times emphasized that perhaps the major problem of psychotherapy was the difficulty of maintaining the communication of accurate or valid data from the patient to the therapist.

July 27, 1954

V. G. MATHISON

2,684,670

ELECTROPSYCHOMETER OR BIOELECTRONIC INSTRUMENT

Filed Aug. 1, 1951

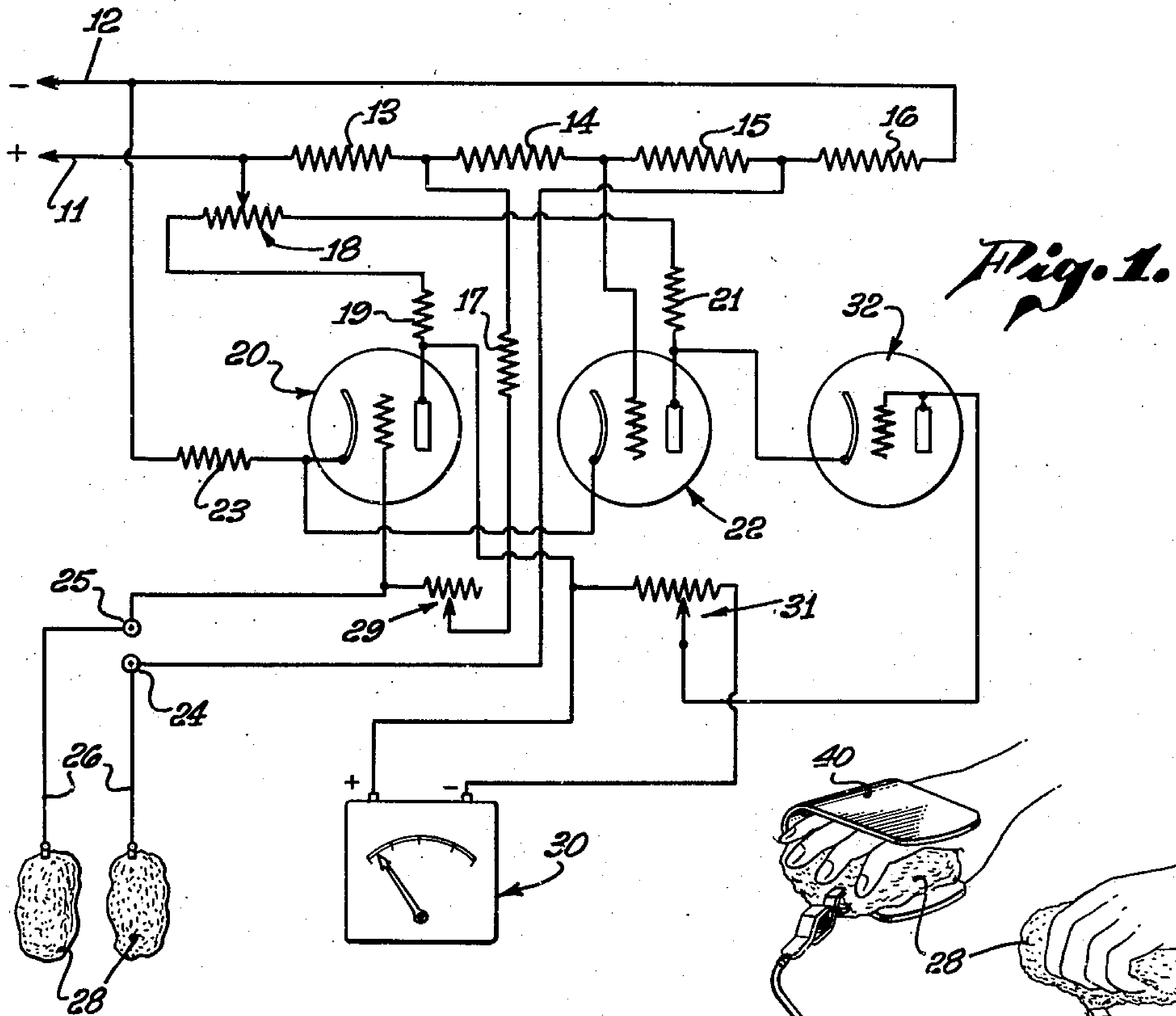

*Fig. 1.*

*Fig. 2.*

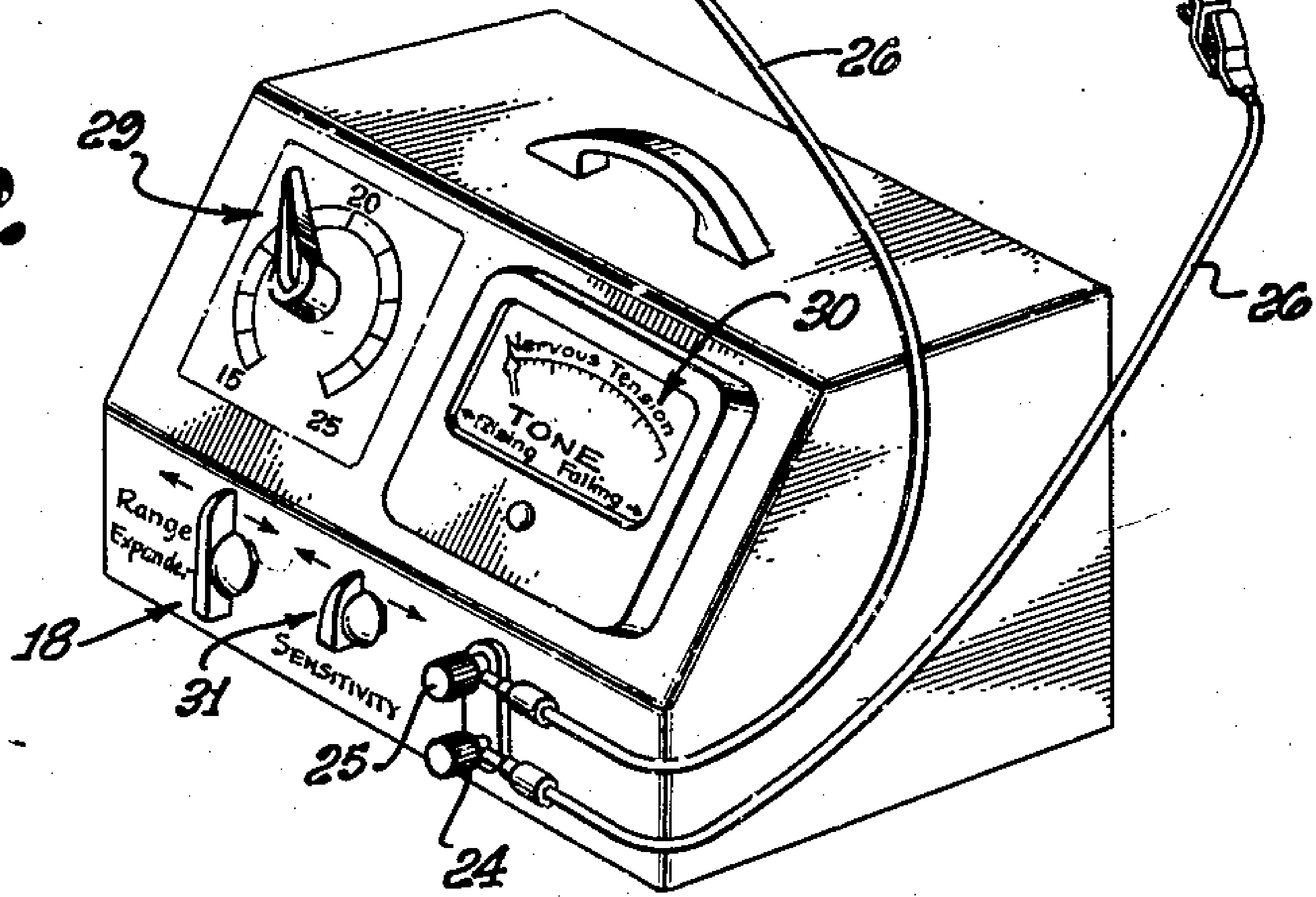

INVENTOR.

*V. G. Mathison*



**Experimental Psychology — 1938  
Robert S. Woodsworth**

THIS MACHINE RECORDS YOUR FEELINGS !

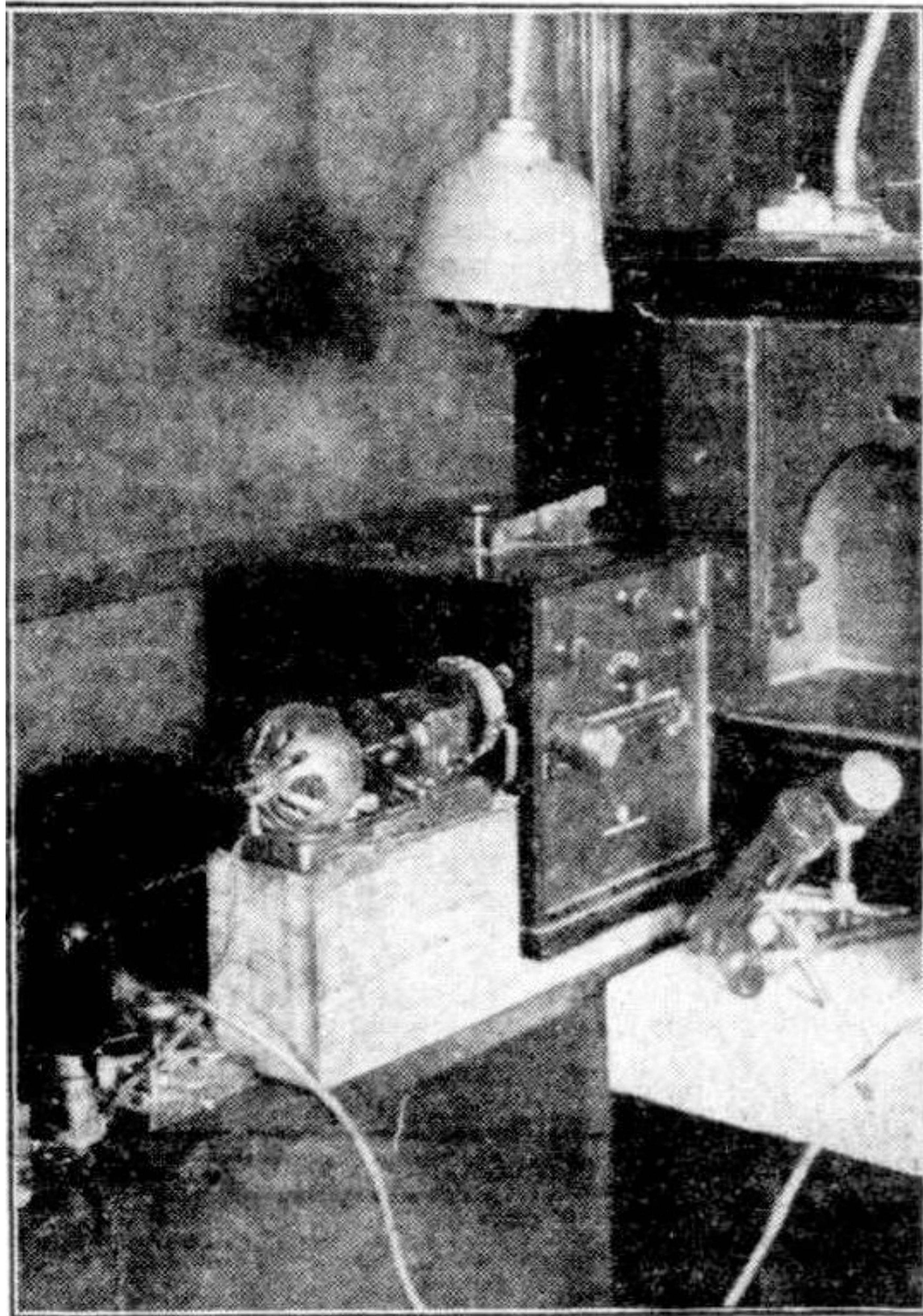

HERE WE HAVE A PSYCHOGALVANOMETER. It has been used in this State by the State Psychologist to record on a special chart changes of feeling or emotion experienced by persons when being questioned. It is attached to the arm during examination.

**Western Australia's Psychological Clinic  
The Mirror — 1930 (Perth, Western Australia)**

# The MONGOLIANS' RAY

By Volney G. Mathison



WHEN Samuel Jones heard all the racket in the corridor outside of his office, he thought that one of the janitors must have started playing bounce-ball with a couple of ash-cans. Then his door opened, quite suddenly, and in clanked a visitor who was clad from head to foot in massive shining steel armor.

Now, since Samuel Jones, ex-deep-sea wireless-operator and a lot of other things, had become accustomed to being encamped in a mahogany-finished sheet-metal pigeonhole up on the thirty-ninth floor of a New York City office-structure, he was not to be jarred by anything; and if the building were to have capsized with him, he would probably have brushed the broken tiles off his coat-sleeve with a debonair yawn, bought a newspaper, and ridden home in the subway, and engaged in reading about the latest scandal in Hollywood.

Nevertheless, he was startled when this towering visitor, encased in polished steel armor, came into his office, clanking like a steam-shovel. The mysterious caller was completely shielded, from helmet to sollarrets, flexible steel shoes, in gleaming metal. Even the gauntlets on his wrists were made of finely-woven chain-mail, and when he raised the trap-door in his helmet, with a bang, his face remained hidden behind a silvery-colored gauze screen. In his right hand, he carried a bulging brown leather brief-case.

Espying this weird-looking monster, Samuel Jones' short-skirted young secretary let out a squeak, and so stiffened in her chair with fright, that she looked like a pretty silk-stockinged artist's model posing in a tightly-wrapped red silk pillow-cover.

"How do ya do, sir?" Samuel Jones greeted the gleaming apparition, in an urbane and New York-like manner, at the same time pressing a button that rang an alarm in three private-detective agencies, and then cautiously pulling open a desk-drawer that conveniently housed a big, worn-looking 5-caliber six-shooter with a long, blued-steel barrel. It was a gun that he had used for sprinkling lead on ornery trouble-hunters, when he had been building a string of wireless-telegraph stations in Alaska.

"You are Mr. Jones?" inquired the armored mystery, in a voice that seemed to carry something of the hollow roll of a bass drum.

"That's me," replied the occupant of the sheet-metal pigeonhole. "Mr. S. P. Jones to my barber, Sam Jones

to my bootlegger, an' that skunk of a Jones to th' crooks that I publish show-up stories about in th' *Mazerka Magazine*."

"It is in reference to this *Mazerka Magazine* that I have called," announced the visitor, in a voice that sounded cryptic.

"Oh, yes, won'tcha sit down?" said Samuel Jones, pulling his desk drawer open about a foot, and wondering if lead-nosed bullets could get through this phantom's shining steel breast-plate.

About this time, the door of the office bulged open, revealing a corridor jammed with spectators. As Samuel Jones afterwards remarked, when New Yorkers act that way, it may be said to be the cow's fingernails.

AS he warily got up and shut the door, his visitor sat down in a chair, with a bump like a colliding box-car full of plowshares, and chipped off a lot of varnish with his forged steel tail-piece.

"Sir, I have read that in connection with this *Mazerka Magazine*, a late billionaire bath-tub maker, has left you a bequest of \$25,000 a year, to be expended, at your discretion, in exposing all sorts of pseudo-scientific frauds, especially those within the realms of chemistry and electricity; for instance, spurious spirit-photographs, electronic-reaction quackeries, and fifteen-cent radio vacuum-tubes."

"That's th' correct dope," replied Samuel Jones, coldly. He closed his desk-drawer and pushed the "all's-well" signal to the three detective agencies; while

his semi-skirted private secretary came to life and began clicking her typewriter again. As Samuel Jones afterwards expressed it, both he and his stenographer could already see the nigger in the steel-pile. The *Mazerka Magazine* got about fifty-seven varieties of "touches" a day, each

one aiming at that \$25,000.

"I," said the armored mystery, "have come to bring to your attention a thing of vastly greater moment than exposés of electromedical sharks and gold-brick kings. Sir, your life is, at this instant, in deadly peril!"

"Huh!" ejaculated Samuel Jones; and he hastily jerked open his desk-drawer arsenal again, about two feet.

"Yes! And not only your life, but the life of every real American in this country. This nation, sir, faces at this instant a secret, a sinister, a terrible peril. We

---

*HERE is a capital scientifiction story that would have done O. Henry honor. It is one of these rare surprise stories that comes along once in a great while. For good science, excellent fiction, suspense and adventure, it ranges high in the list of scientifiction stories.*

*We know you will enjoy it!*

---





While the armored mystery looked on, the investigator of scientific frauds got up and walked over to look at the fantastic apparatus on the laboratory table. Curiously he fingered one of the electrical controls on the switchboard beside the instruments

# Mathison-Quiz Meter

A fascinating and extremely sensitive device! Has a 1U4 tube which operates on A and B batteries.

For beginners, students, and for experimental self processing.

Warranty Notice: This instrument is a modification of the "Marlin Meter." Changes include the addition of practical cords, and electrodes, and other items. Delivery in first-class operating condition is guaranteed, but no further warranty is extended. A-battery operates about 6 hours of actual use; B-battery about 50 hours of actual use. A-battery 55c. B-battery \$1.95.

**EXCHANGE PRIVILEGE:** Quiz Meter may be returned within two months, regardless of condition, provided plastic case is unbroken, for \$20 credit on a Mathison Electropsychometer.

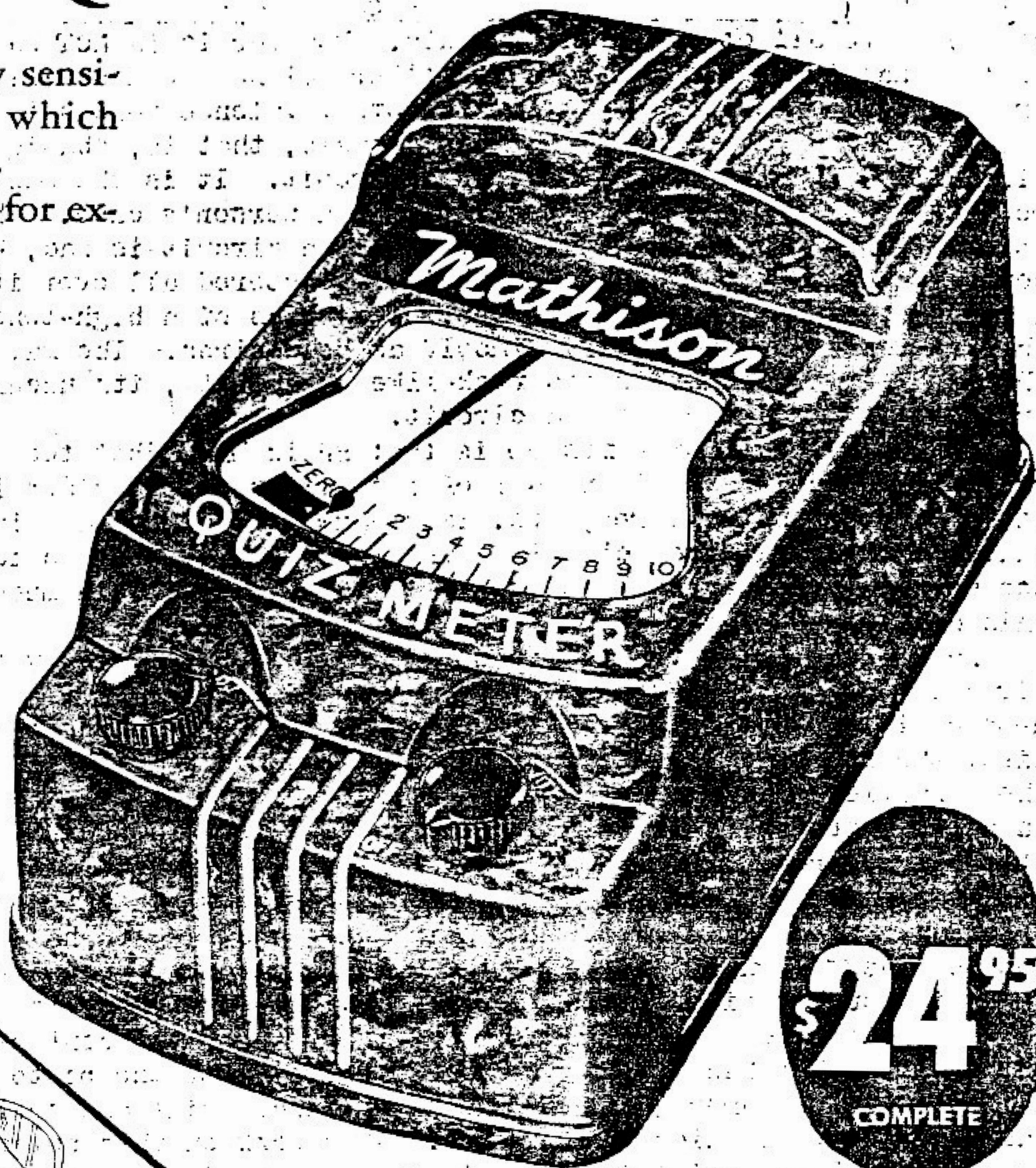

**\$24<sup>95</sup>**  
COMPLETE

Party fun, too!

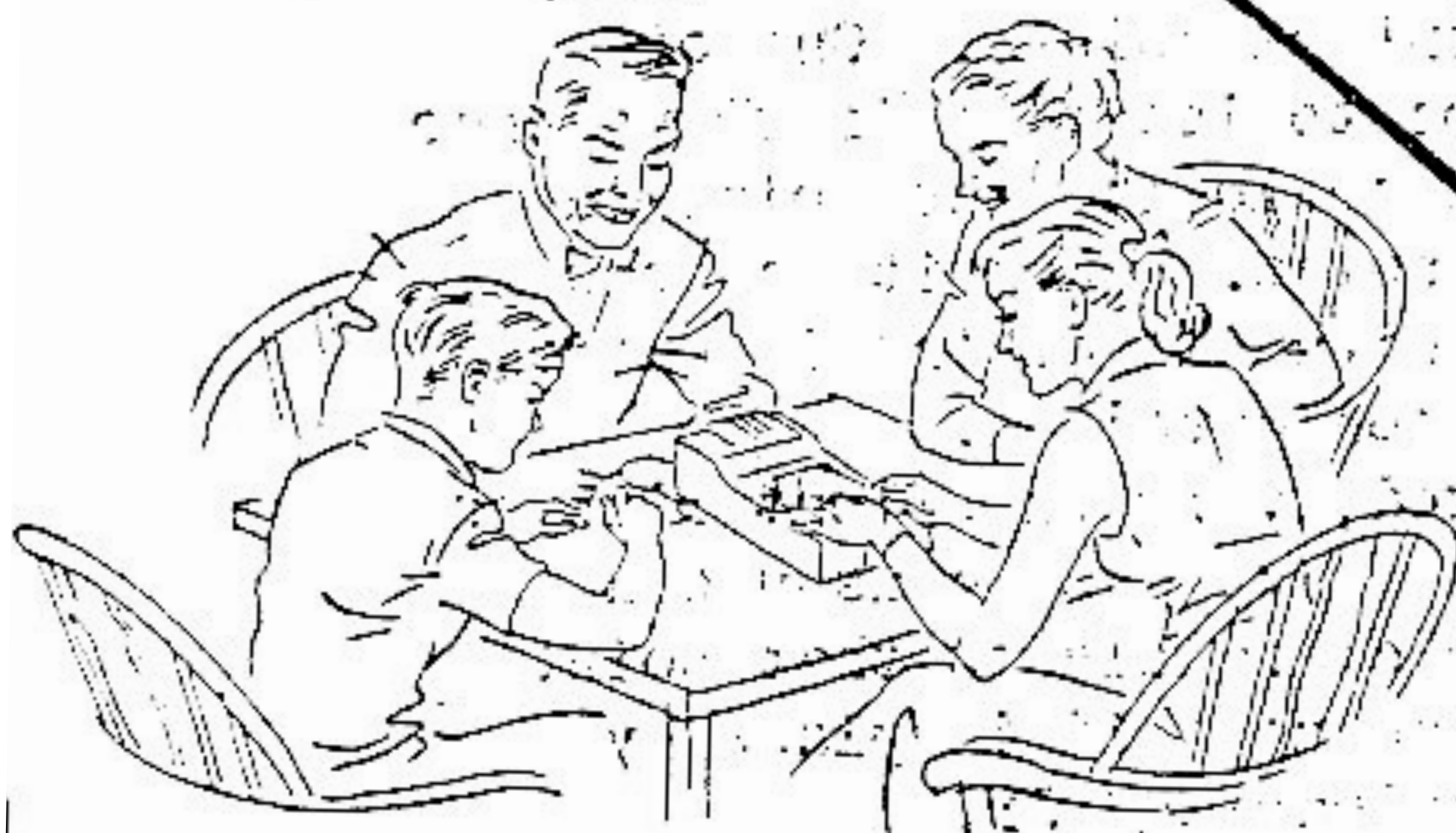

Instructions for party use included with each instrument. See "Sample" below.

Ask a girl to decide secretly which boy present she would most prefer to be kissed by. Instruct her to say "NO!" to every question you are about to ask. Then ask: "Is it John?" "Is it Harry?" "Is it Dick?" etc. When you come to the young lady's actual selection you will get a pin-hitting needle surge.

Discloses the location of anything lost or mislaid. Answers the question "He loves me... he loves me not," etc. Bear in mind that embarrassing questions may be asked by a tactless, low-toned quizzer. Be careful!

SOLD BY:

Price includes cords, can electrodes, operating instructions, and copy of bulletin "Case Opening Material" by Volney G. Mathison. Also party-fun instructions.

OR: Complete with stainless steel instep electrodes, 12-ft. deluxe cords, two extra A-batteries, and copy of manual ELECTROPSYCHOMETRY by L. Ron Hubbard and Volney G. Mathison. \$31.50

#### ACCESSORIES

Stainless steel instep electrodes and metatarsal elastic straps. Recommended for use instead of hand electrodes. Price, with 3 pair of retaining straps	\$2.40
Deluxe 12-foot cords, per pair	\$2.40
Manual "ELECTROPSYCHOMETRY" by L. Ron Hubbard and Volney G. Mathison, 1963 edition	\$1.85
A-Battery (Burgess #2-D)	\$0.55
B-Battery (Burgess #XX-30)	\$1.95
1U4 Tube	\$2.70

Trademark Reg.

U.S. Pat. Office

Quiz-Meter

**ARCON SALES CO.**

ELECTRONIC SPECIALTIES

1214 WEST 30TH STREET

LOS ANGELES 7, CALIFORNIA, U. S. A.

Reprint from

## FORTNIGHT

CALIFORNIA'S OWN NEWSMAGAZINE

Now sit back easily and think of a big, rusty nail! Think of stepping on it and the excruciating pain as it enters the tender flesh of your foot. . . .

If you're like most of humankind this image you conjure up will give a momentary flash of what is called in the vernacular the Screaming-Meemies. Indeed, your stomach may even break into a finale of the Ballet Russe. But, among the more erudite who flit about in the high ethereal reaches of Psychiatric theorizing, you are just experiencing a jolt and a jar at the loci of psychic trauma. If the image so upsets you that you hurry angrily out, hat in hand, to beat a hardware merchant about the head and shoulders the chances are that your loci is bigger than a watermelon and you ought to have it looked over.

Measuring the degree of psychic trauma is the function of a new machine called the "Electropsychometer" which was devised by Inventor Volney G. Mathison who is also active in psychoanalytical research. One day he set about designing a machine that would aid psychiatrists in measuring nervous reactions. First, he knew that when a person sees or feels or hears something unpleasant there is a spontaneous tightening of muscles. While this reaction is so finite that the person may not notice it, it can be measured. Similarly, a pleasant reaction causes a person to relax. So here was one human reaction which could be measured. Secondly, the human skin is covered with approximately 400 sweat glands per square inch. On the thumbs and fingers, however, this rises to a dramatic 2700 per square inch. What is called the "psychogalvanic reflex" manifests itself in the jetting of droplets of saline fluid from subcutaneous glands. The sweat glands are closely allied with the autonomic nervous system and respond with extreme rapidity to nervous impulses originating in the autonomic nervous system. When a hand starts to clasp, for example, the jetting has *already* occurred.

**The Chore.** With these two basic facts

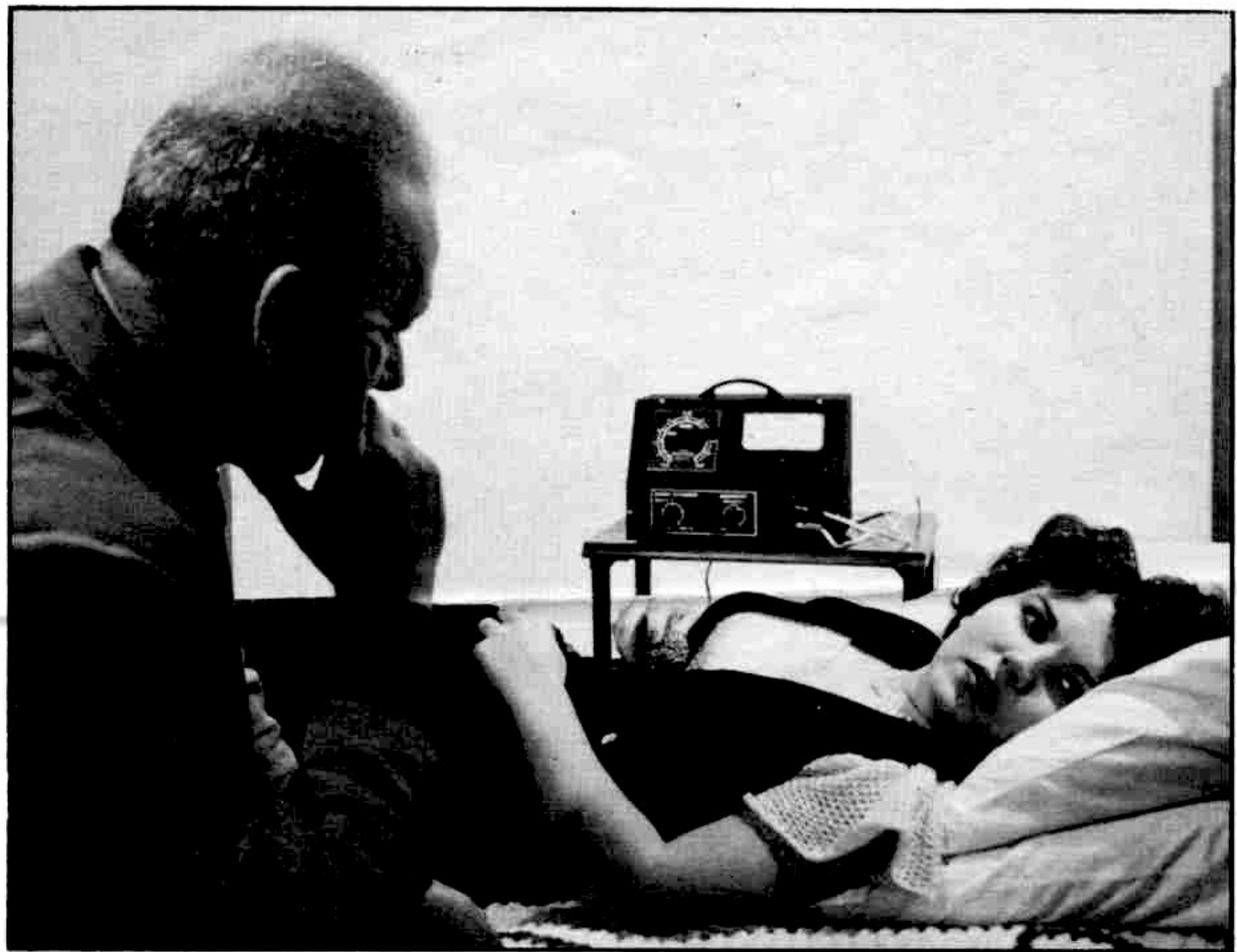

Volney G. Mathison analyzes a patient on the Electropsychometer.

Mathison set to work. When the pilot model of his machine was built he started testing patients. The patient held two pads. The machine, delicately measuring muscular reaction, shows an upsurge on the dial when a question which was painful to the patient was asked. But the sweat gland measurement was still not so easily measurable. Mathison finally hit upon the simple idea of using an ordinary kitchen scouring pad for the patient to hold. The results were immediately satisfactory; the tiny fibers of metal measured the degree of "jetting" accurately and transmitted it to the machine.

A long series of tests began. The dial was adjusted to show pleasant and unpleasant reaction to questions. If there was a muscle-tightening and increased "jetting" it meant that the questioner had hit upon a painful subject. If there was relaxation it meant the patient found the question pleasing and soothing.

The dial registered, in effect, nervous tension. If a person is asked a question which is of no real concern to the patient the needle on the dial remains stationary. But, if the question is a painful one, the needle points toward a state of nervous tension and *stays there*. The "tone" of a patient is, also, measurable by the machine and the tone scale set up by Mathison runs from 4.0 (a healthy person in deep and dreamless sleep) to 1.0 (a state of acute physical and psychic disturbance). The "tone" scale measures the energy-consuming activity of the autonomic nervous system. It may be affected by such

things as external stimuli, the patient's bodily condition or complex mental-physical activity such as "feelings" and "thoughts." Mathison found that it takes time for each new patient to adjust to the machine and, only by some primary testing, could the accurate "tone scale"—or the rate of energy consumption—be ascertained. Once a patient became used to the machine and relaxed, the degree of tension could be judged. From that point on the reaction to questions becomes pertinent.

**Application.** The review of painful past events then begins. The studies include not only sexual situations, but also illnesses, frustrations, losses of beloved persons, and a vast variety of other injurious occurrences in the patient's life history.

It is also said that the instrument enables the therapist to avoid "running his own case" instead of the patient's case. In research, both patient and analyst are connected to two separate instruments, and Mathison observes both instruments. The analyst will often "hit the pin" in response to one of his own questions, while the patient's instrument may surge slightly, or not at all. This means that the area in review is more painful to the therapist than it is to the patient. Erroneous evaluations on the case are then inevitable, Mathison thinks, without instrumentation.

Also under research is a technique whereby differentiations between psychosomatic anxieties and actual organic illnesses apparently may be observed.

# MATHISON ELECTROPSYCHOMETER

new approved foot contacting  
electrodes available.

Many substitutes for the hand-gripped electrodes furnished with the Mathison Electropsychometer have been proposed, such as finger-stalls, rings, thimbles, bracelets, and the like. These are old devices, long since discarded. Their low efficiency is one of the reasons why the psychopulsionic reflex effect was not much used in the field of psychotherapy before the advent of the Mathison Electropsychometer.

Dr. Lloyd C. Neely, a Los Angeles psychiatrist, has introduced efficient foot-contacting electrodes, consisting of curved stainless steel plates which are strained against the soles of the bare feet with elastic straps. Muscular-reflex registrations, obtainable only with hand-gripped electrodes, are lost; but owing to the large areas contacted and the extreme sensitivity of the feet of most subjects, good results are obtained.

Price per pair, with elastic straps \$3.40.  
16-foot deluxe cords \$2.40 per pair.



Dr. Lloyd C. Neely demonstrates foot-contacting electrodes with the Mathison Electropsychometer.



## Free Needle Instrument

All Model H-53-DS Electropsychometers are now being furnished with an FN-53 chassis. This embodies a simplified and practical form of the delicate circuit originally furnished to L. Ron Hubbard and used by him in the development of Scientology.

The FN-53 chassis has a new added control (not shown in this picture) whereby the instrument may be operated in the usual manner, or with a 90% free needle, for the user who is advanced enough to interpret the sensitive registrations that are sometimes observed. The free-needle instrument probably comprises the final modification of the basic invention, which has now been brought to a high level of flexibility, without any change in the fundamental mode of functioning.

Time payment price \$96.50. Down payment \$24.50, nine payments of \$8. Less 10% for cash, net \$86.85.

Prices are F.O.B. Los Angeles, Calif. Shipping weight 17 lbs.

St. Louis Dianetic  
Society e/o

SOLD BY:

RICHARD G. KERLIN  
8349 ARCHER AVENUE  
UNIVERSITY CITY 14, MO.

Manufactured under license by  
**ARCON MFG. CO.**  
1214 WEST 30TH STREET  
LOS ANGELES 7, CALIFORNIA, U.S.A.

# MATHISON ELECTROPSYCHOMETER

8 patent claims conditionally allowed April 24 1952. 16 claims pending.

SOLD BY: The Office of L. Ron Hubbard  
1405 North Central  
Phoenix, Ariz.

"Bluntly, auditing can't be at optimum without an electropsychometer. The things one can now bring up from the psychophysical depths of the human personality, and the violence of the charges often found in them, can be handled successfully only through the use of this instrument."

—L. Ron Hubbard

Phoenix, Ariz., April 5, 1952

Dear Volney:

"With the advent of the 1952 dianetic techniques, your electropsychometer became a tool so vital in processing that I actually do not know how an auditor can work without one; and know certainly that an auditor who does try to work without one sacrifices the reality of his preclear, and at the very minimum quadruples the amount of time he should put on the case.

"When I can demonstrate the machine to auditors, they ordinarily stop auditing without one. It is necessary to know exactly where the preclear is... an auditor auditing without a machine reminds one of a hunter hunting ducks at pitch black midnight, firing his gun off in all directions.

"I didn't wake up to how revolutionary your instrument was until I recalled days of talking with engineers two years ago trying to get them to build such a device. It is completely impossible to have an instrument like the Electropsychometer. I have the word of RCA and Bell on it! In the earlier days at Elizabeth, I had access to an electroencephalograph and every other then known type of bio-electronic instrument. They all proved utterly useless. The electropsychometer is the only one that works.

"In your instrument we have something far more certain and reliable than any one has ever had before. I expect this machine to go far and wide. Mostly because it means better auditing, higher reality, and fewer spins. Your machine is sturdy. I dragged one all over the country and it is still operating. I think you have made a great and real contribution, and I deeply appreciate your sincerity and ability."

—L. Ron Hubbard

Manufactured under license by  
**ARCON MFG. CO.**  
1214 WEST 30TH STREET  
LOS ANGELES 7, CALIFORNIA, U.S.A.

Registers relative degrees of dynamic psychophysical stress from moment to moment during the dianetic auditing session. Indicates the approximate Hubbardian tone-scale of the preclear from 1.0 to *infinitely high ranges!* Immediately discloses points of entry into "armored" or "shut-off" cases. Enormously raises the "sense of reality" of both the auditor and the preclear.



Model H-52-IR      \$98.50 complete fob Los Angeles.

Operating data and instructions furnished with each instrument. Requires no difficult adjustments.

"Electropsychometric Auditing" by L. Ron Hubbard.  
A short manual. \$2.00. Free with each instrument.

All instruments subject to return for cash refund after ten-day trial, provided seals unbroken.

Shipping weight, domestic 17 lbs.; foreign (boxed) 36 lbs.

Warranty: Meter-analyzer movement is not warranted against burnout caused by tampering with seals or by misuse of instrument. Every instrument is otherwise guaranteed for one year against failures due to defective materials or workmanship. Safe delivery guaranteed.

"This instrument is a major development — make no mistake! When used in combination with the new 1952 techniques, it enables any fairly good auditor to obtain top-level results." — L. Ron Hubbard

## MATHISON ELECTROPSYCHOMETER

Now approved foot contacting  
electrodes available.

Many substitutes for the hand-gripped electrodes furnished with the Mathison Electropsychometer have been proposed, such as finger-stalls, rings, thumbtacks, bracelets, and the like. These are all devices, long since discarded. Their low efficiency is one of the reasons why the psychogalvanic reflex effect was not much used in the field of psychotherapy before the advent of the Mathison Electropsychometer.

Dr. Lloyd C. Neely, a Los Angeles psychiatrist, has introduced efficient foot-contacting electrodes, consisting of curved stainless steel plates which are strained against the soles of the bare feet with elastic straps. Muscular-reflex registrations, obtainable only with hand-gripped electrodes, are lost; but owing to the large areas contacted and the extreme sensitivity of the feet of most subjects, good results are obtained.

Price per pair, with elastic straps \$3.40.  
16-foot deluxe cords \$2.40 per pair.



Dr. Lloyd C. Neely demonstrates foot-contacting electrodes with the Mathison Electropsychometer.

VII. Agreement has been reached with Volney G. Mathison, inventor of the Psychogalvanometer, to permit the Hubbard College to act as sole agent throughout the world except for cities of New York and Los Angeles. H.D.A.'s can secure a 20% discount on the Psychogalvanometer which retails at 128.50. We are making immediate delivery.





# PSYCHIATRY

AN INDUSTRY OF DEATH

# MUSEUM

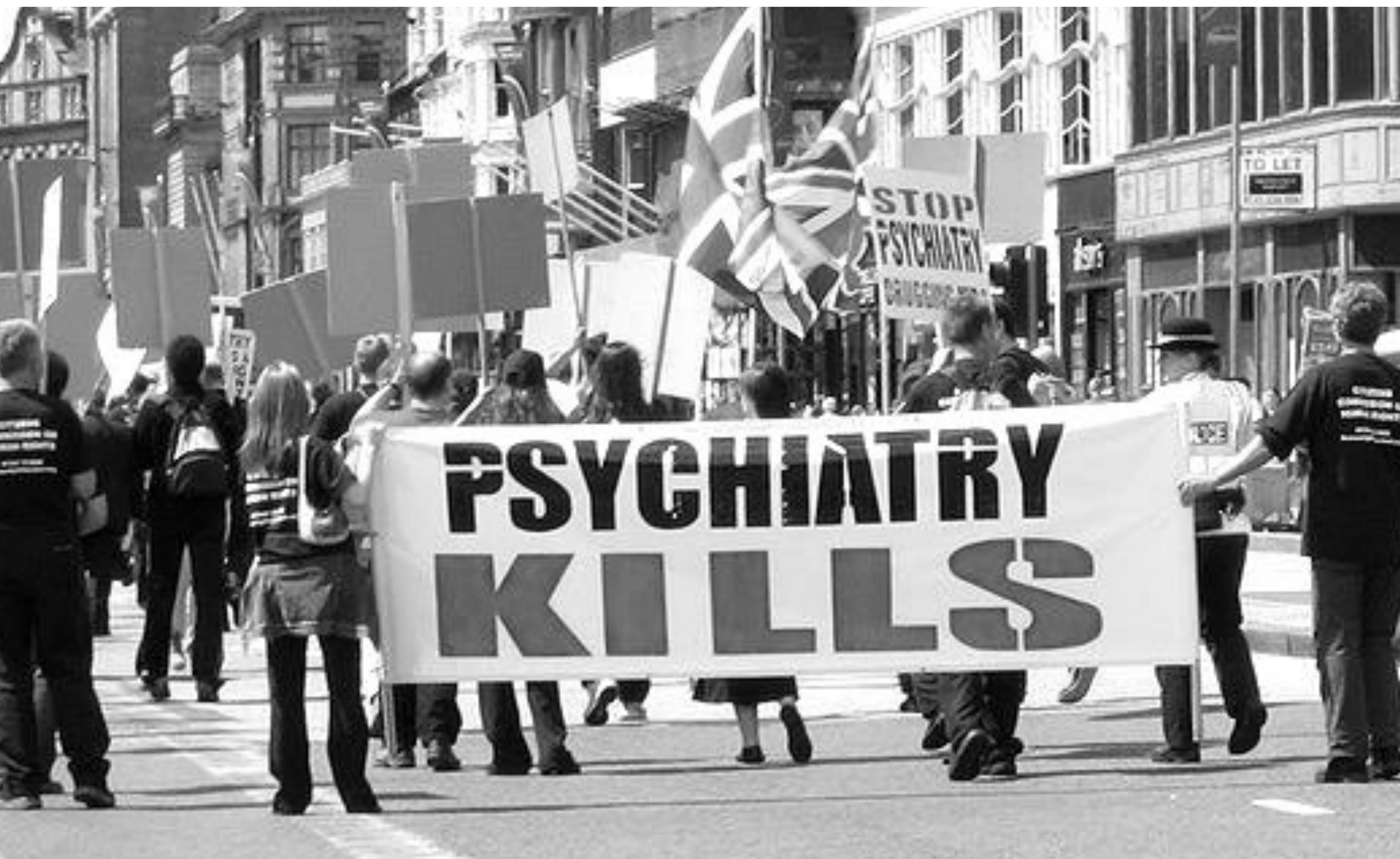



**EMETER**

# E-METER

In itself, this E-Meter does nothing. It is an electronic instrument that measures mental state and change of this state in individuals. The E-Meter is not intended or effective for the diagnosis, treatment or prevention of any disease.

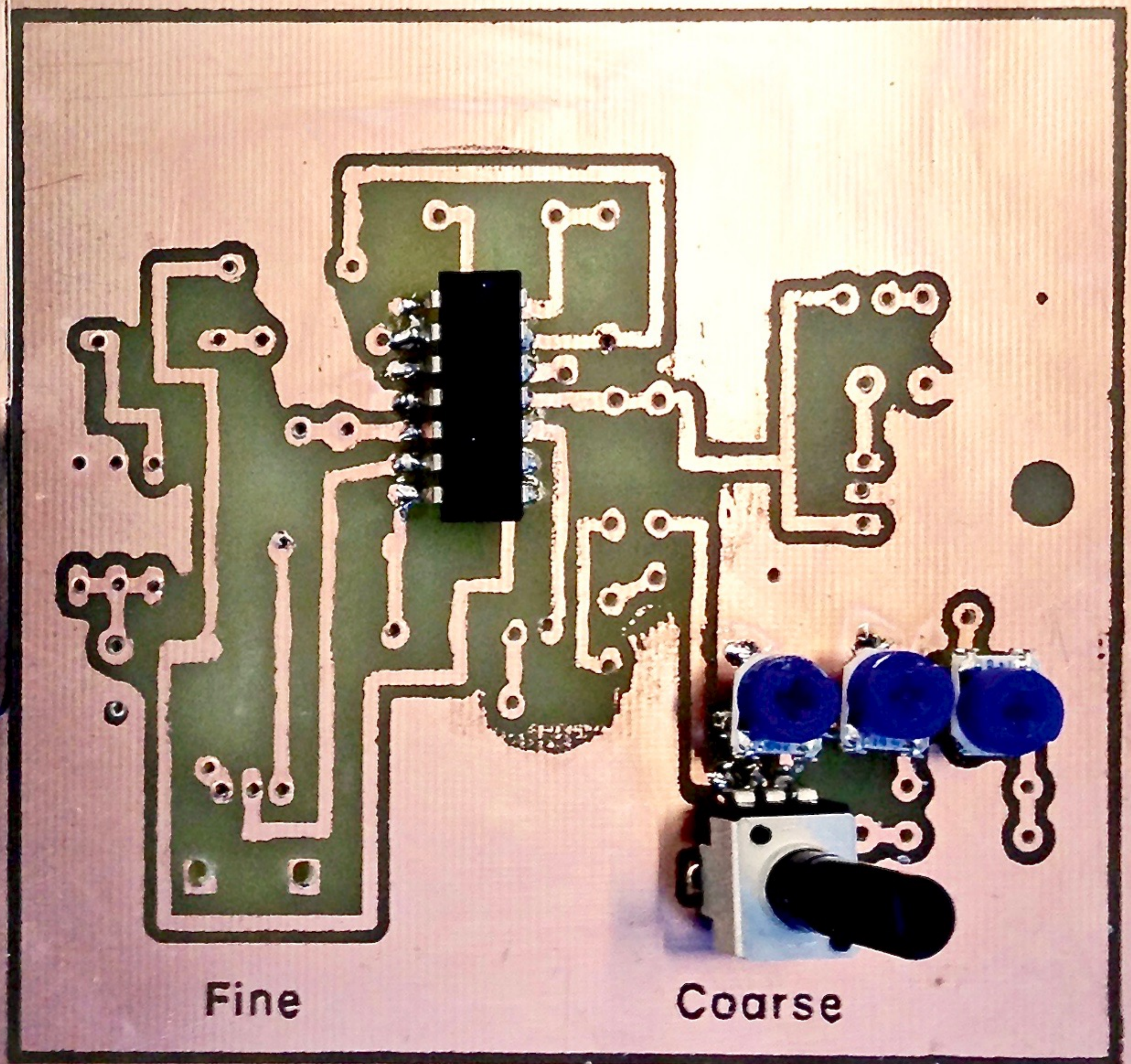
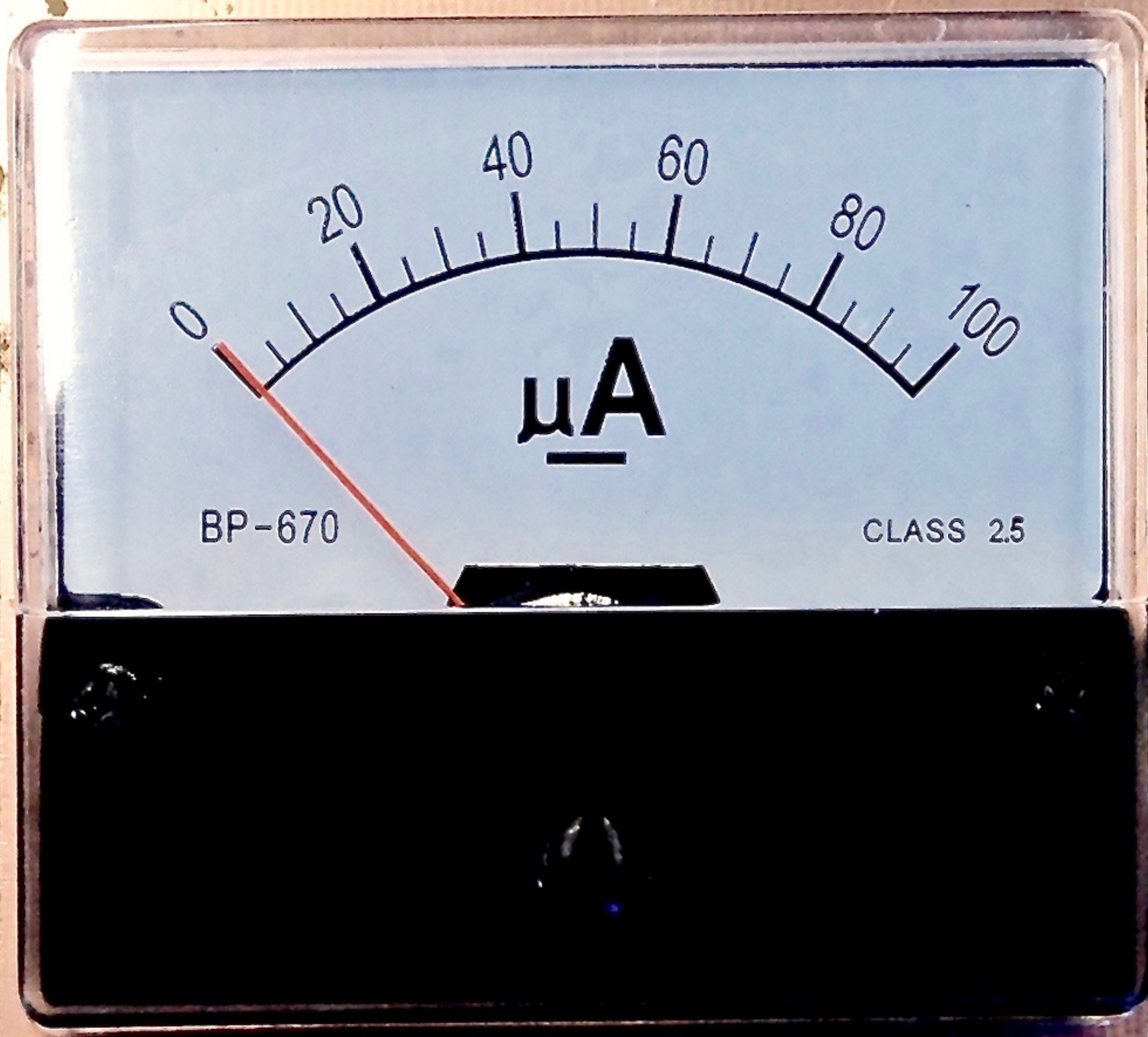

Shintaro Miyazaki / Jamie Allen / Moritz Greiner-Petter (2015)  
Designed and printed at Critical Media Lab Basel / No rights reserved

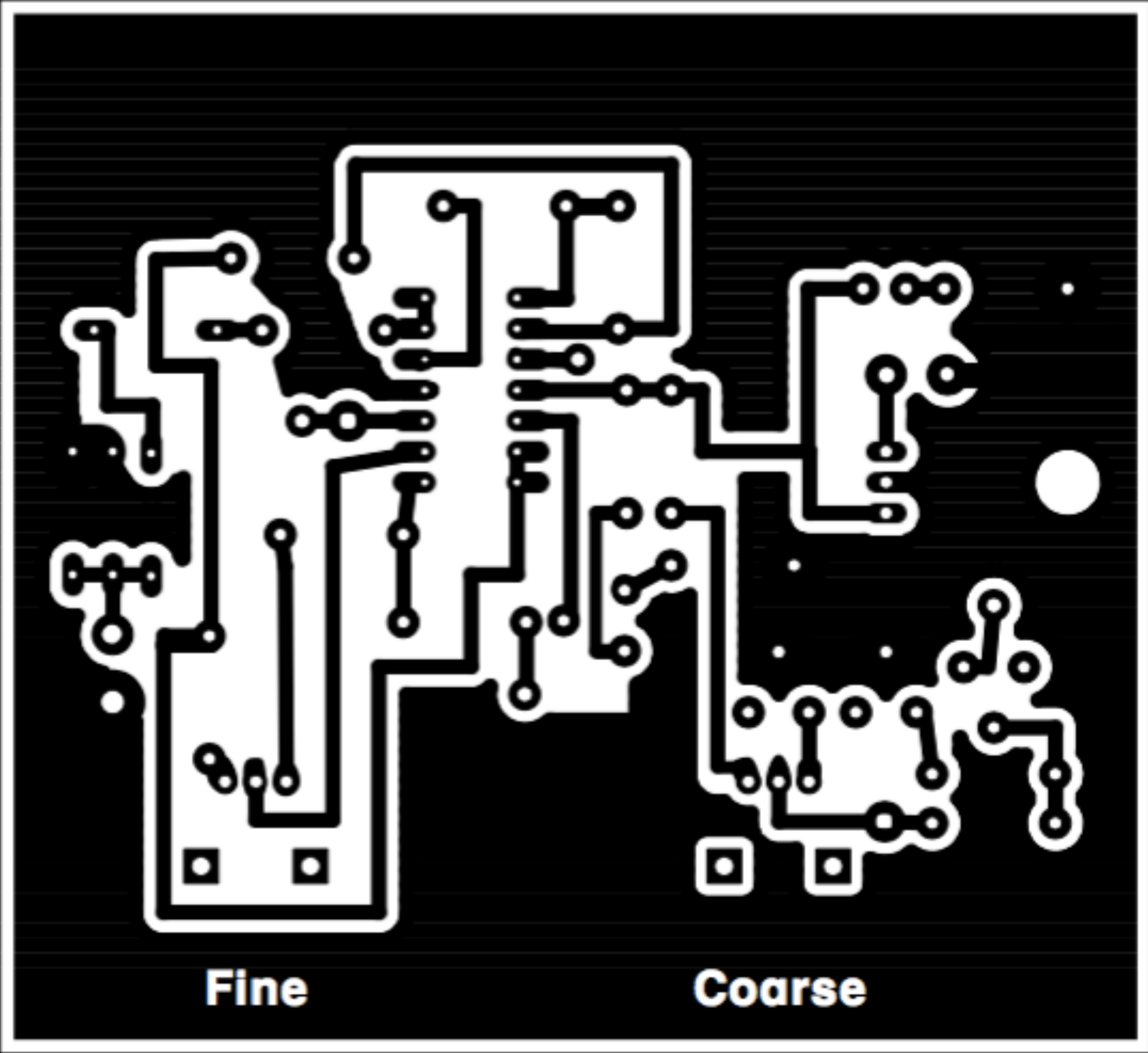

**Fine**

**Coarse**

This is like the "Mark Five E-meter" (dynamic Ohm-meter or polygraph) in which some ex-Syndicate-Scientologist had the "courage" to replace the antique, 40-year-old transistors with modern Operational Amplifiers (OP AMPs), and he calculated the resistors around these, necessary to keep these semiconductor amplifiers within their range and desired amount of amplification. He put some silicon diodes around the microAmpere-meter in order to protect it. The sensitivity and reliability of this polygraph (biofeedback meter) is much better than the 4,600 USD "Mark Super VII E-Meter" sold by the Scientology Syndicate. (If you want "Mark Super VII Quantum" then you increase the Body-shunt resistor of 22 kOhm by a factor five or so, and adjust accordingly.)

The cost of THIS meter, which is better than the 4,600 USD meter, would be under 50 USD. (An extra needle-movement, of 100 milliAmpere for instance, can be added in parallel to the 100 microAmpere moving-coil meter to keep seeing bigger Reads that go "off the dial" of the 100 microAmpere-meter.) A simple analog multimeter (fast moving-coil with needle, or fast, fine bargraph) can be used easily if at hand.

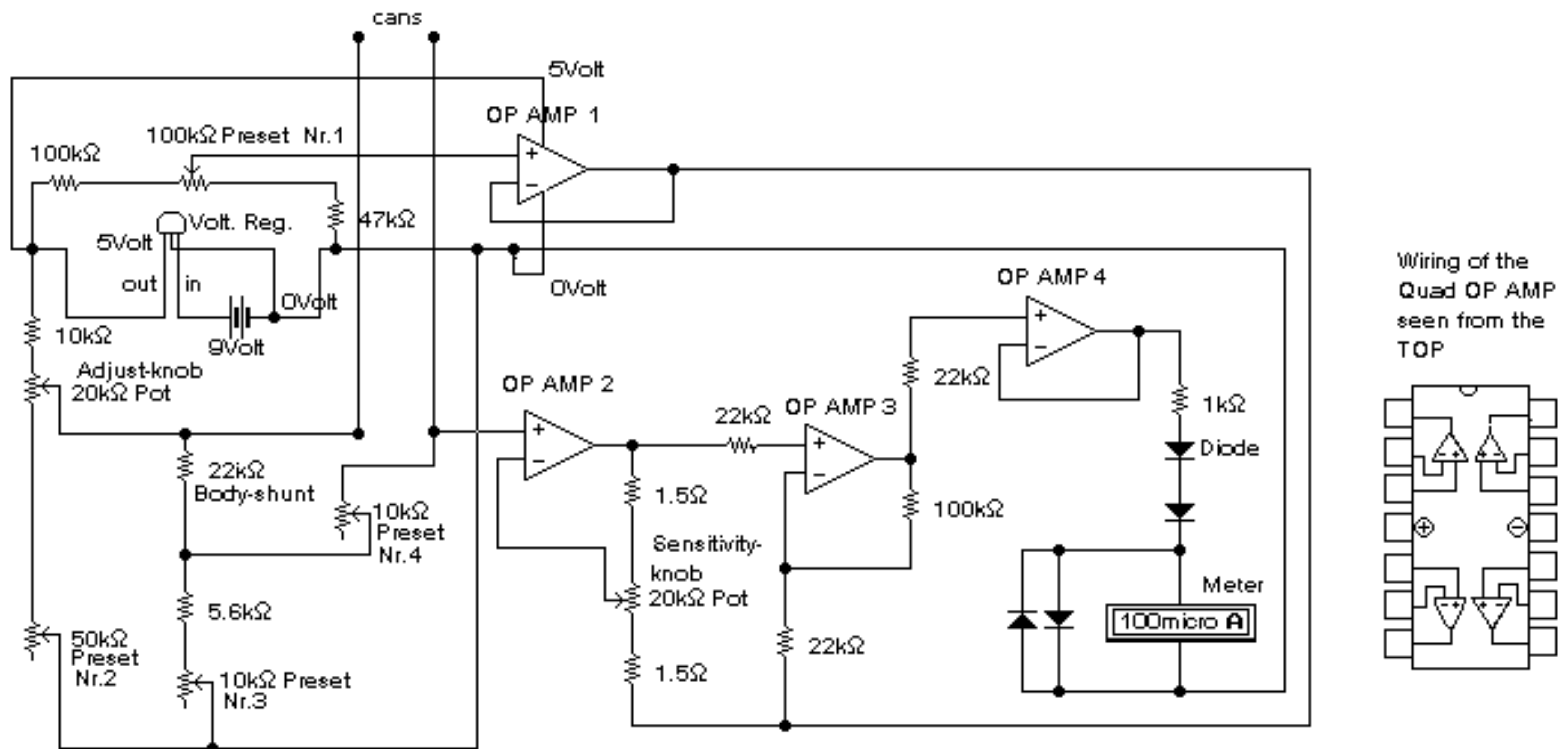

**PARTS LIST:**

- |                          |                     |                            |                               |
|--------------------------|---------------------|----------------------------|-------------------------------|
| 2x 100 kOhm              | 1x Preset 50 kOhm   | 1x Mounting Board          | 1x Voltage Regulator 5 Volt,  |
| 1x 47 kOhm               | 2x Presets 10 kOhm  | 1x 9 V Battery and         | 100 milliAmpere               |
| 4x 22 kOhm               | (All 10% tolerance, | Battery Connector          | (gives stable 5 Volt from any |
| 1x 10 kOhm               | carbon-type)        | 1x Plug and Socket for the | 9 Volt battery)               |
| 1x 5.6 kOhm              | 4x Silicon Diodes   | wire (5 feet) to the Cans. | 2x Knobs: LARGE Adjust-knob,  |
| 2x 1.5 Ohm               | 1x 100 MicroAmpere  | For Cans, small tin soup   | and the Sensitivity-knob      |
| 1x 1 kOhm                | Meter (moving coil) | cans can be used, each     |                               |
| 2x Pots 20 kOhm (linear) | 1x Quad OP AMP      | held in one hand.          |                               |
| 1x Preset 100kOhm        | (for instance       |                            |                               |
|                          | LM324)              |                            |                               |

**SETTING THE PRESETS:**

- Nr.1 - To set the output of OP AMP 1 to roughly 1 Volt or so that, when the needle is at 40 microAmpere, at "set", increasing and decreasing the sensitivity hardly changes the needles position.
- Nr.2 - Set at 50% (For Scientologists: to trim to "TA 3.0", with a resistance of 12.5 kOhm across the cans).
- Nr.3 - With the Adjust-knob at maximum voltage to the Cans, to set the meter needle to read 40 microAmpere with the Cans disconnected (open circuit).
- Nr.4 - Set at 50% (For Scientologists: to trim to "TA 2.0" with a resistance of 5 kOhm across the cans).

(For Scientologists: The Adjust-knob is called "Tone Arm")  
 The Adjust-knob ("Tone Arm") should be of large size. It has to be changed constantly and smoothly, also in very small amounts. (Someone might like to replace the Adjust-pot with a pot that moves several turns around, or might add such a pot.)  
 Contrary to some belief-systems, the sensitivity should be always set at the highest workable level and may be adjusted frequently from high sensitivity to low, and back to high.

(Scientologists make a scale around the "Tone Arm" with historic numbers - minimum is 0.5, maximum is 6.5)

Wiring of the Quad OP AMP seen from the TOP

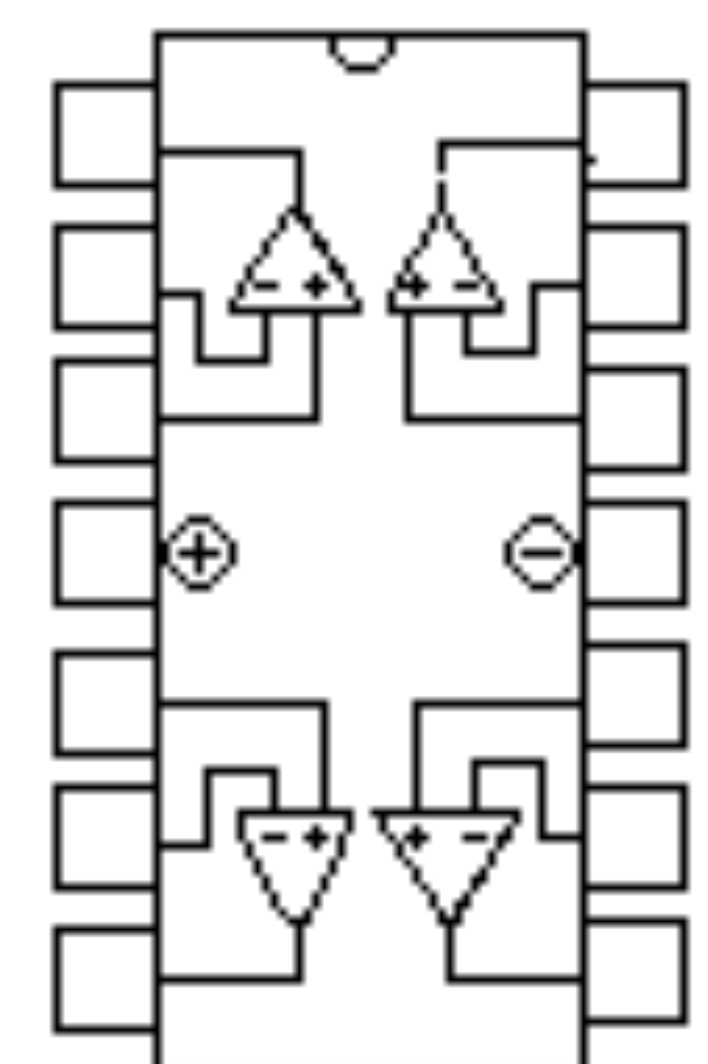

I wish you good hunting and to become free of all the tremendous and unimaginable evil that has, by spiritual means, been done to you and others in various past lives, especially that inflicted upon you and others by the beings L. Ron Hubbard and Richard Reiss. see R1-1056i 'Operating Spiritually Level One (OSLO) - The Technique'

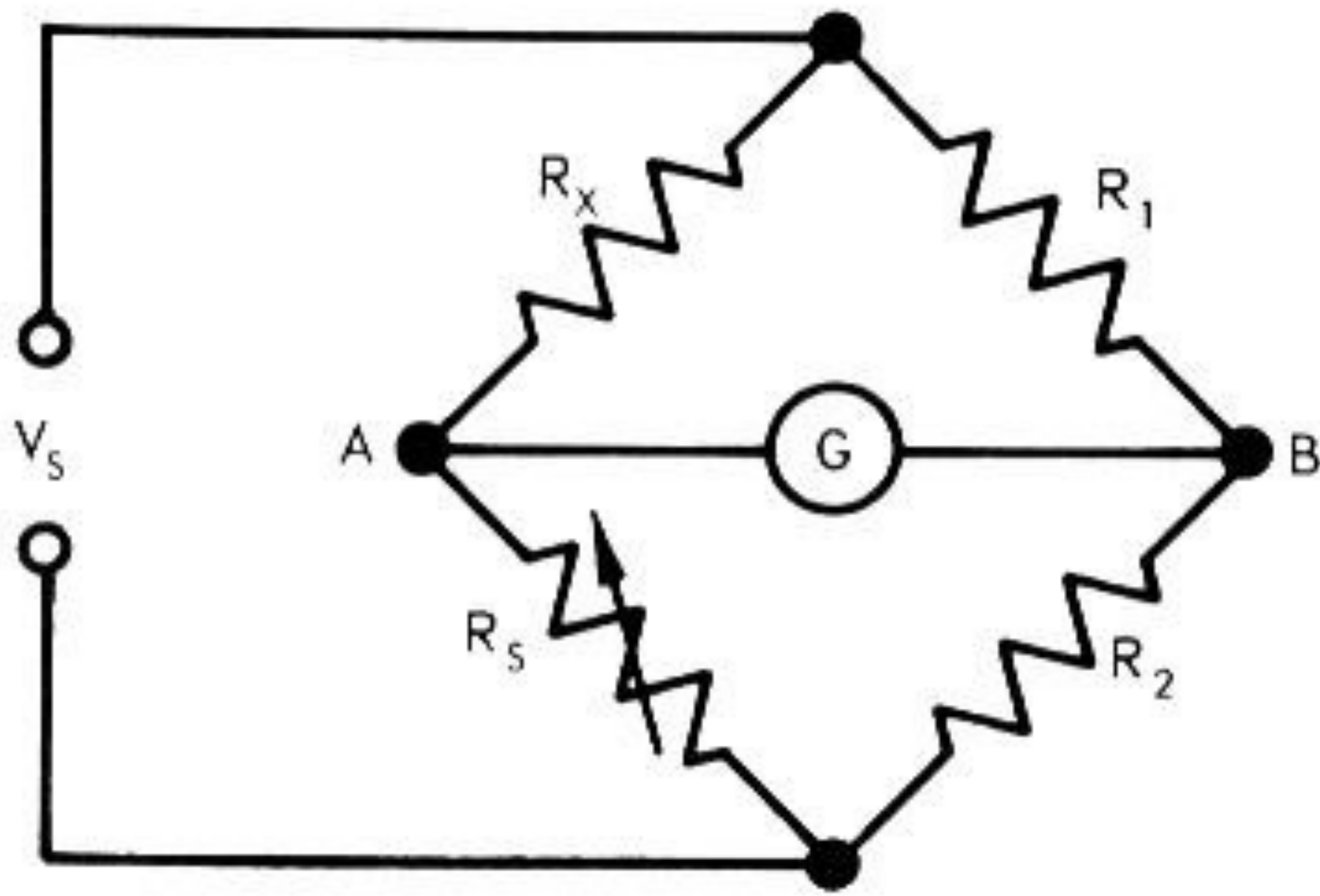

**Wheatstone Bridge**

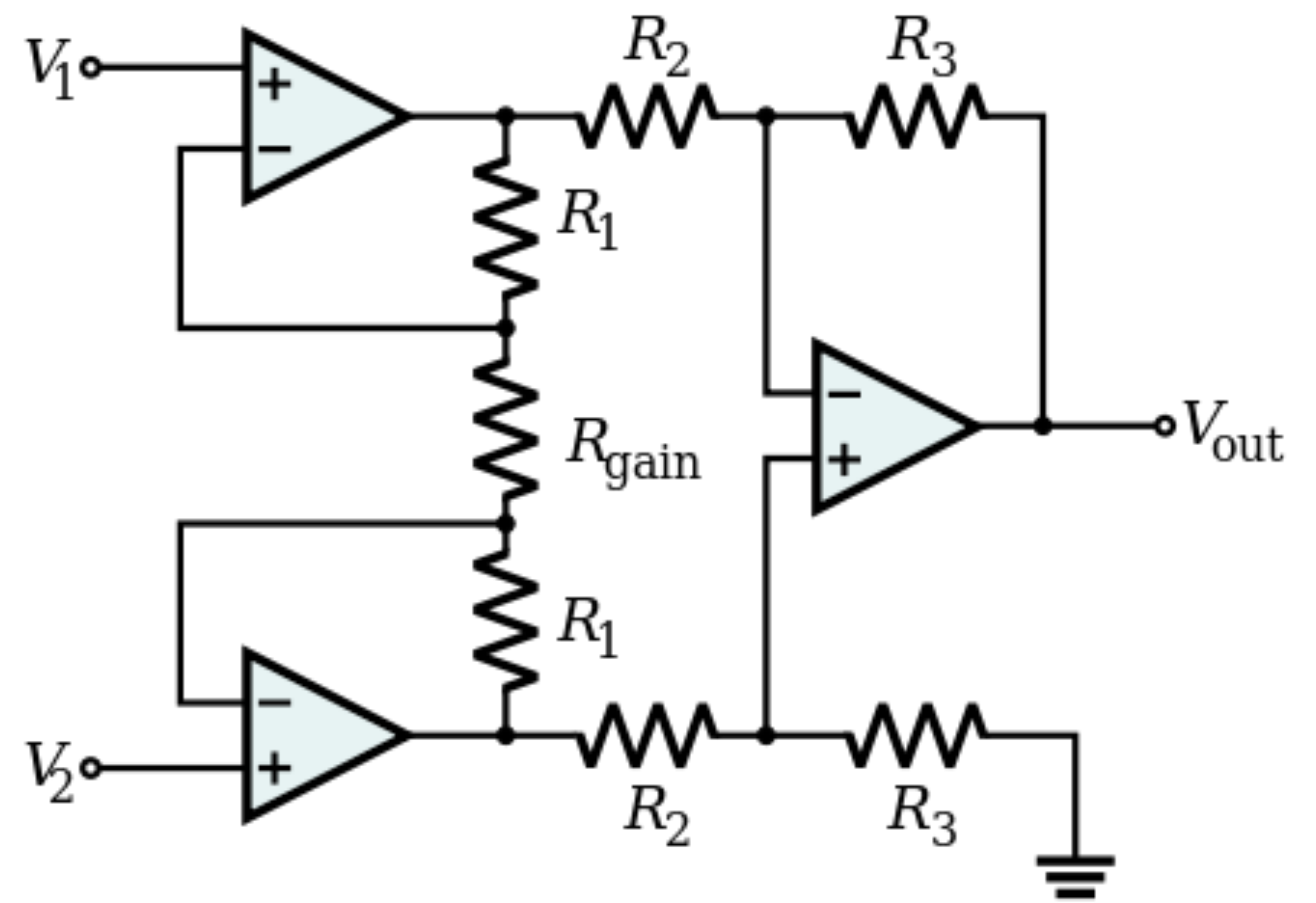

**Instrumentation amplifier**

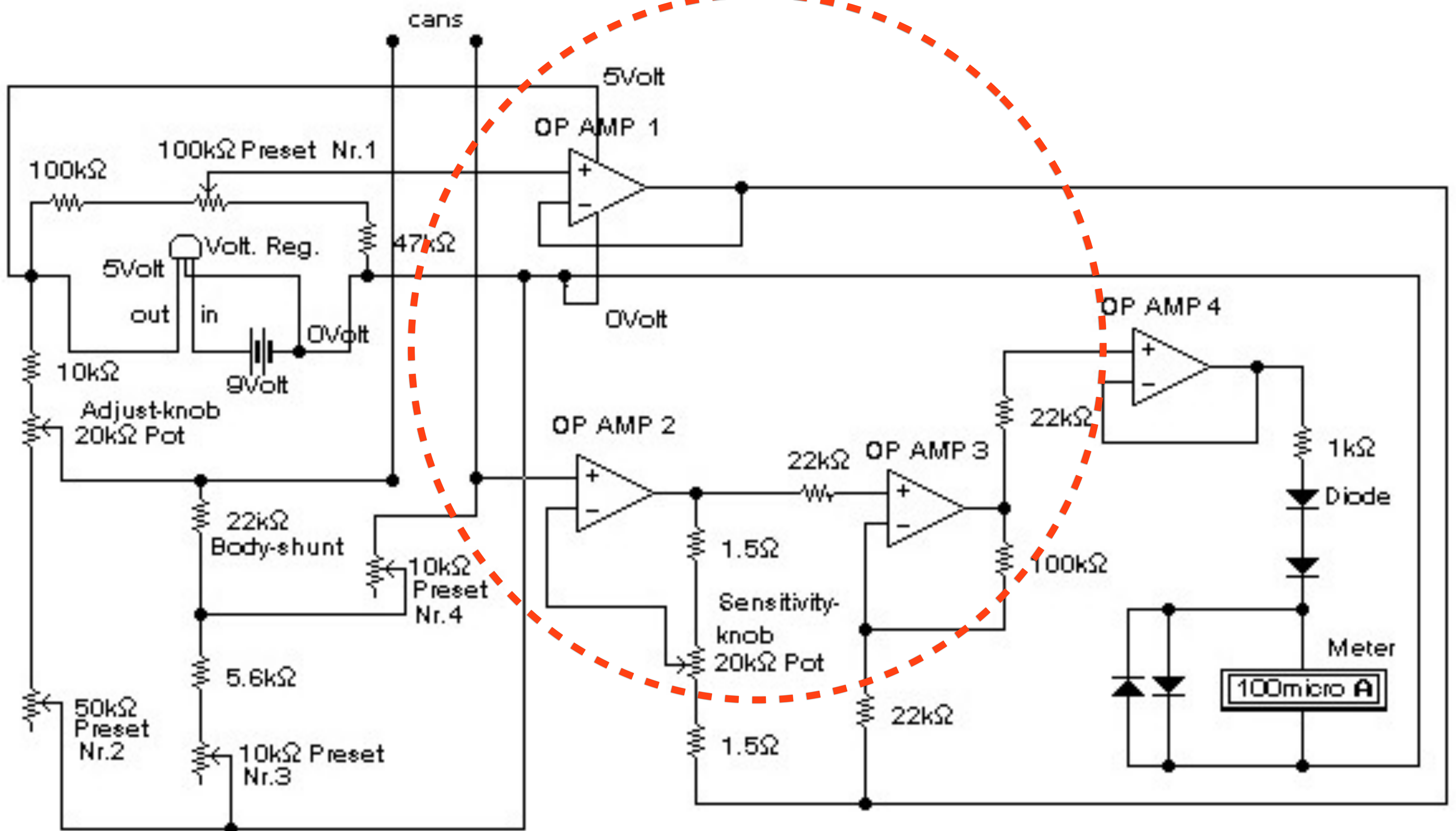

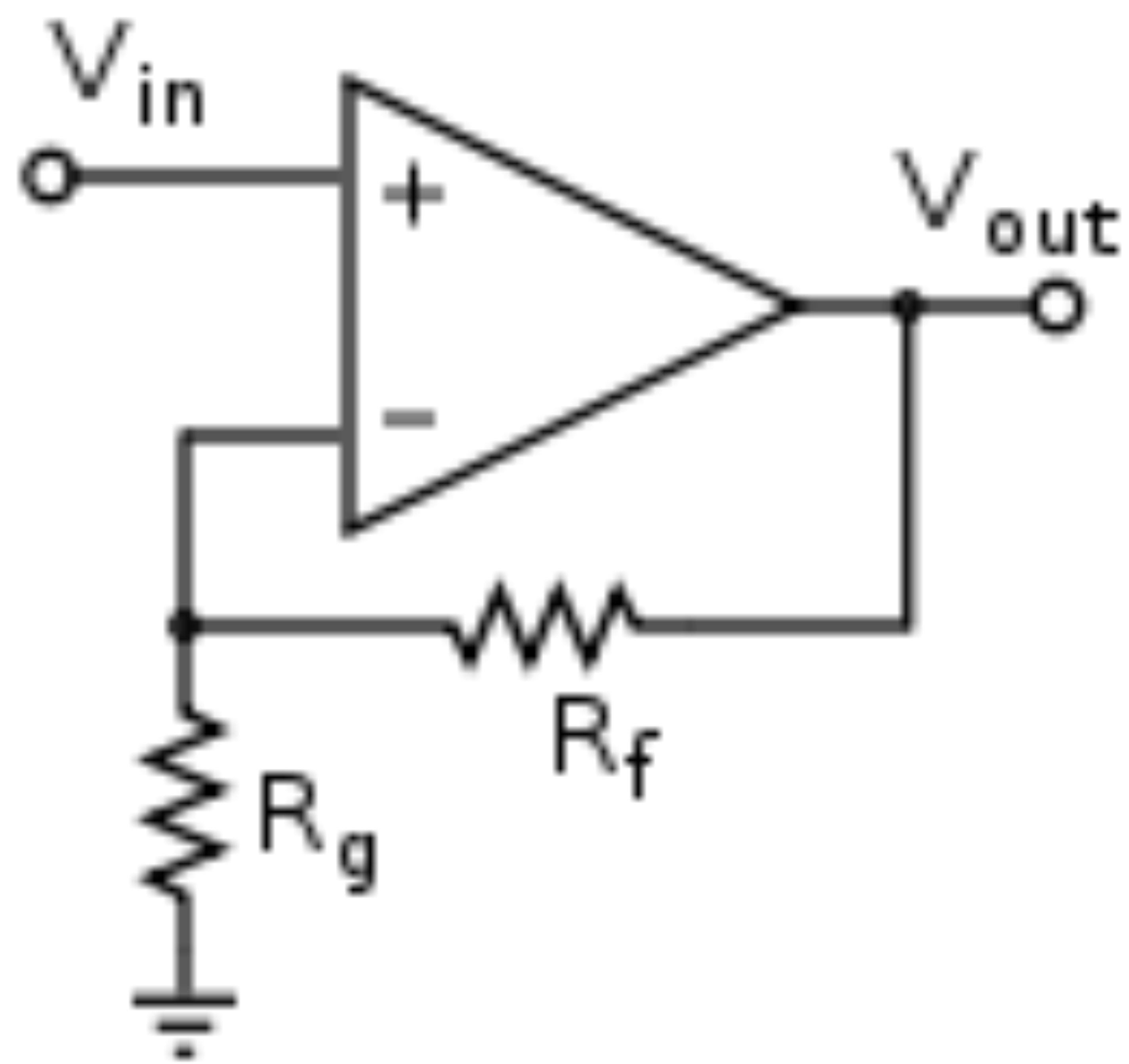

*STABILIZED FEEDBACK AMPLIFIERS*

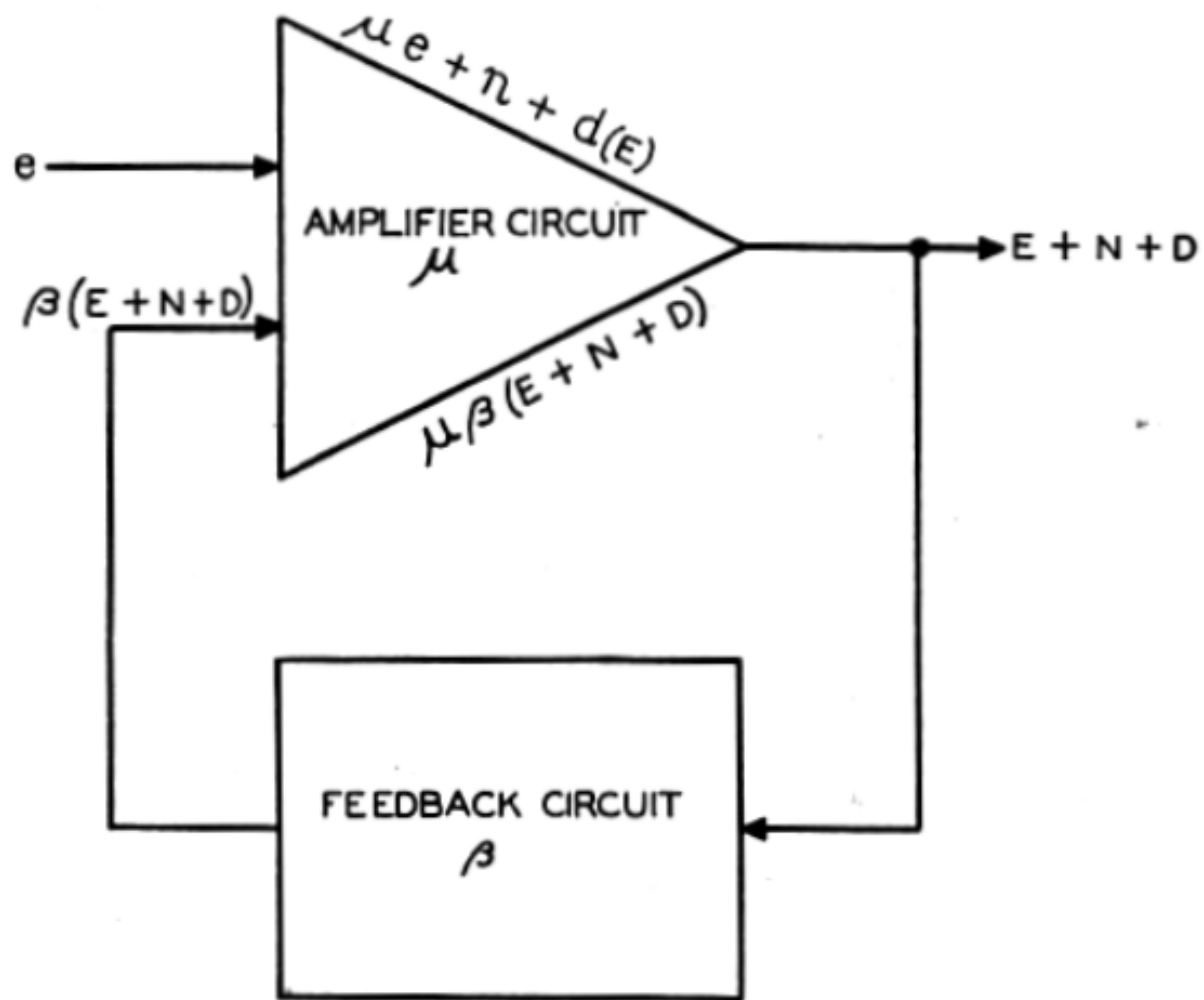
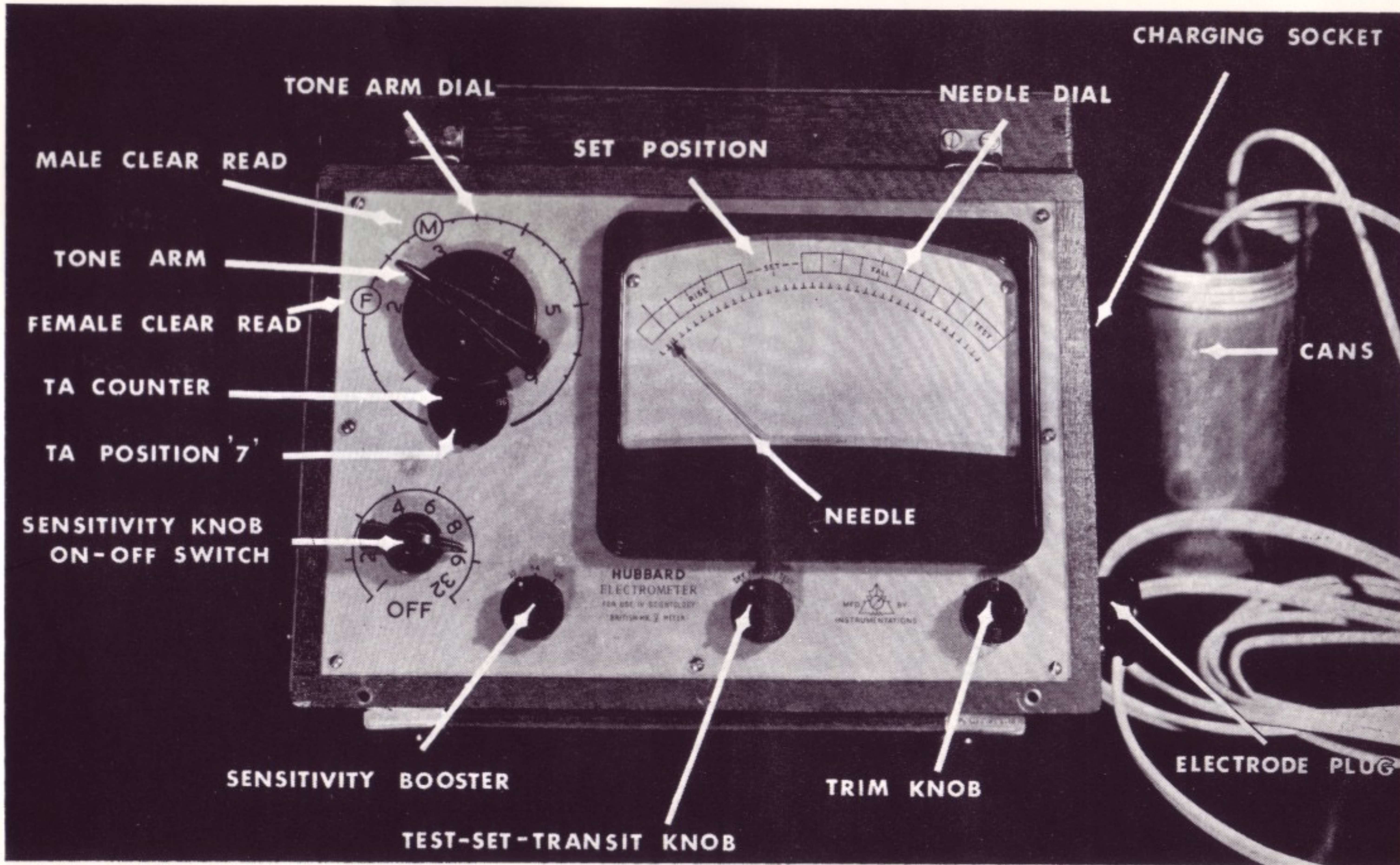

Fig. 1—Amplifier system with feedback.



**THE MARK V E-METER**

# E-METER

In itself, this E-Meter does nothing. It is an electronic instrument that measures mental state and change of this state in individuals. The E-Meter is not intended or effective for the diagnosis, treatment or prevention of any disease.

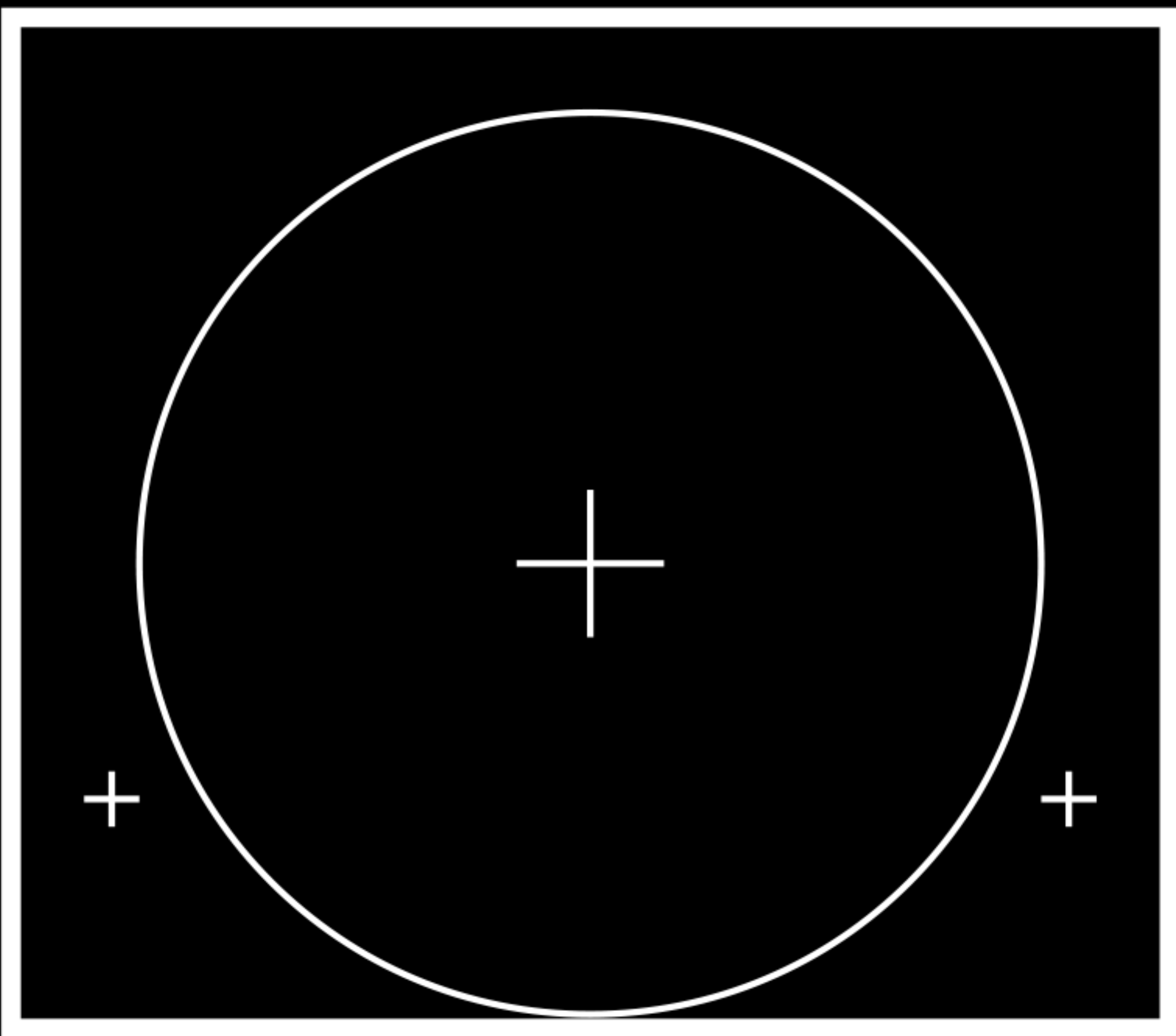

L



R

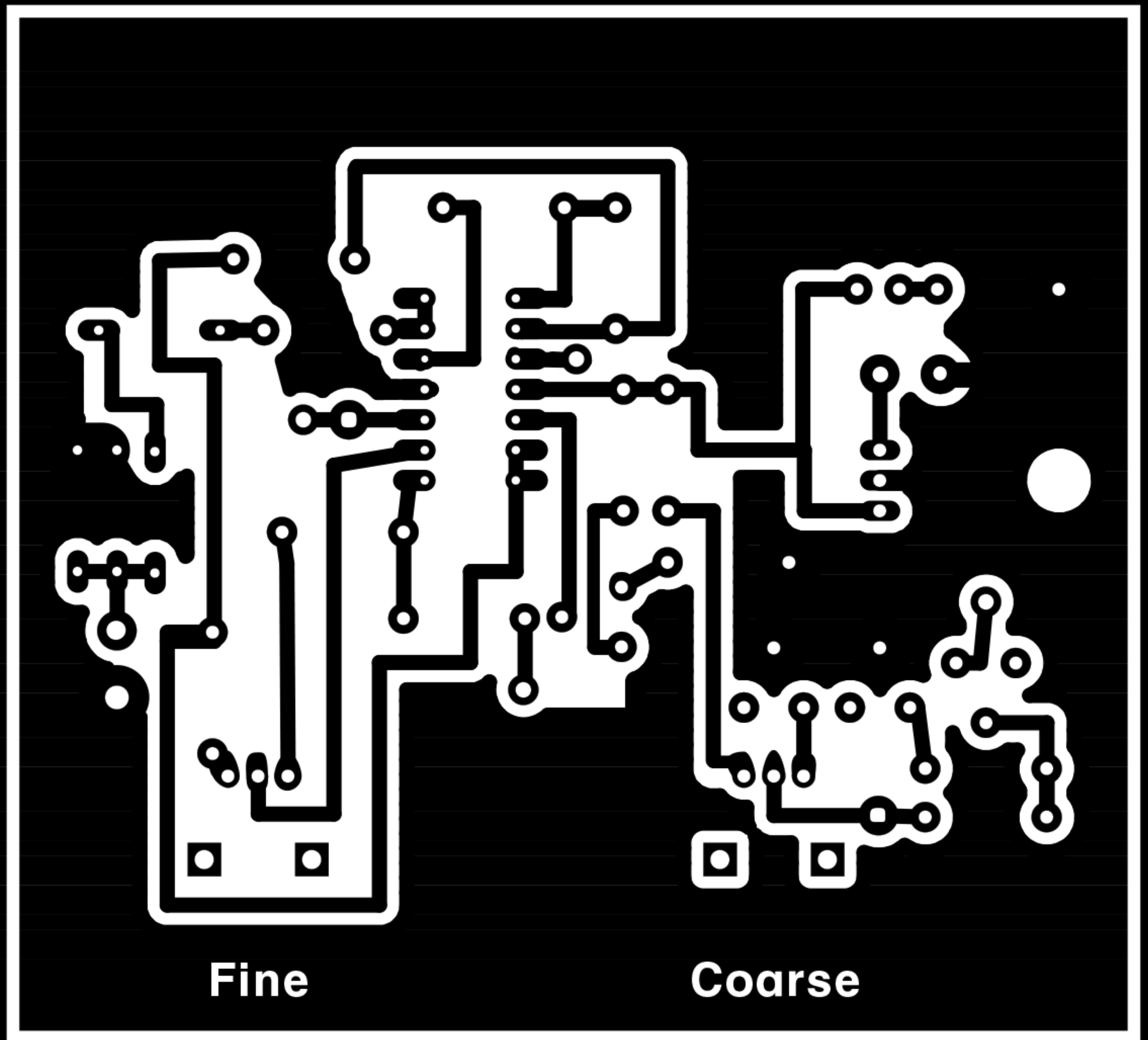

Shintaro Miyazaki / Jamie Allen / Moritz Greiner-Petter (2015)  
Designed and printed at Critical Media Lab Basel / No rights reserved



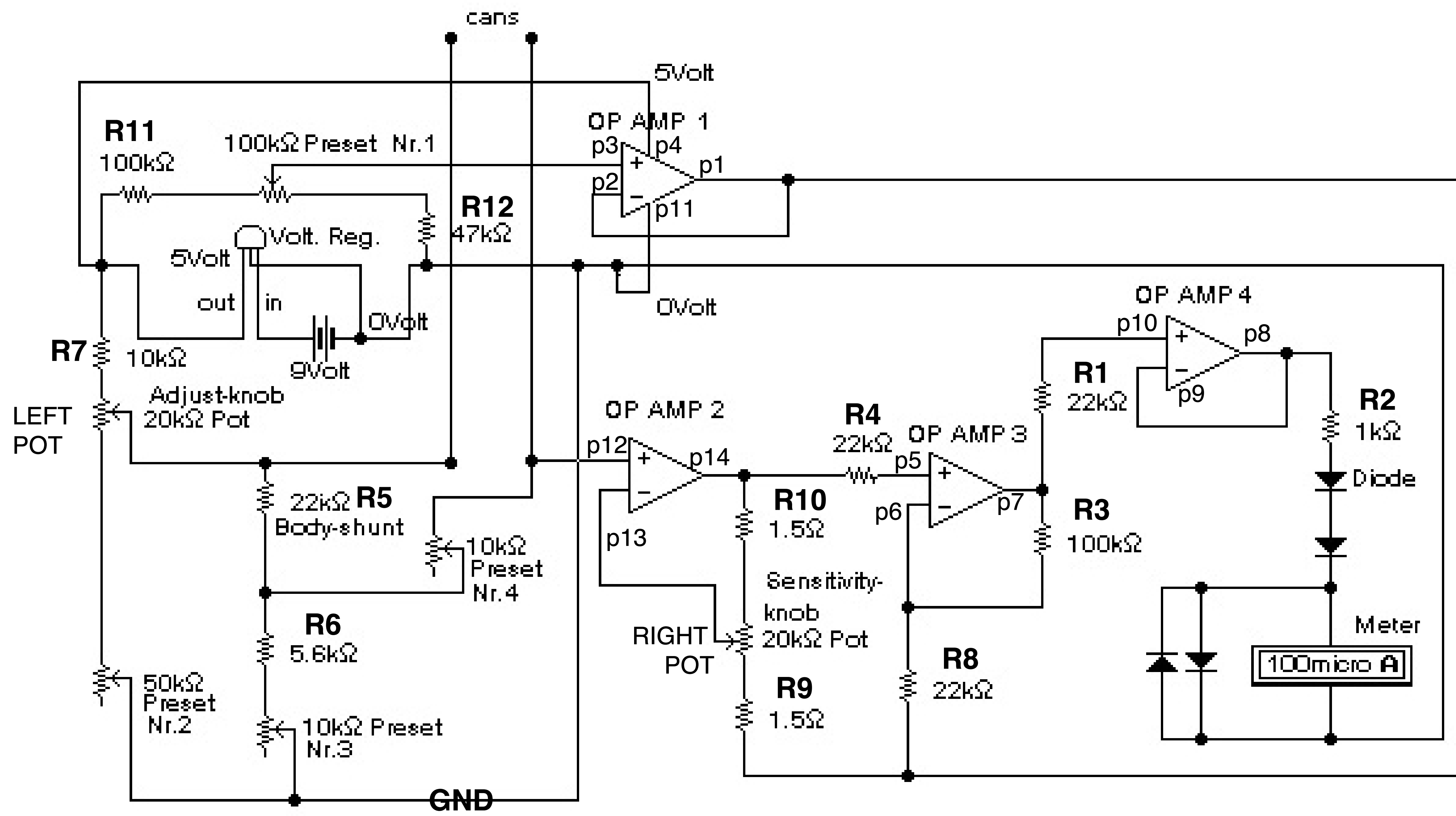

Wiring of the Quad OP AMP seen from the TOP

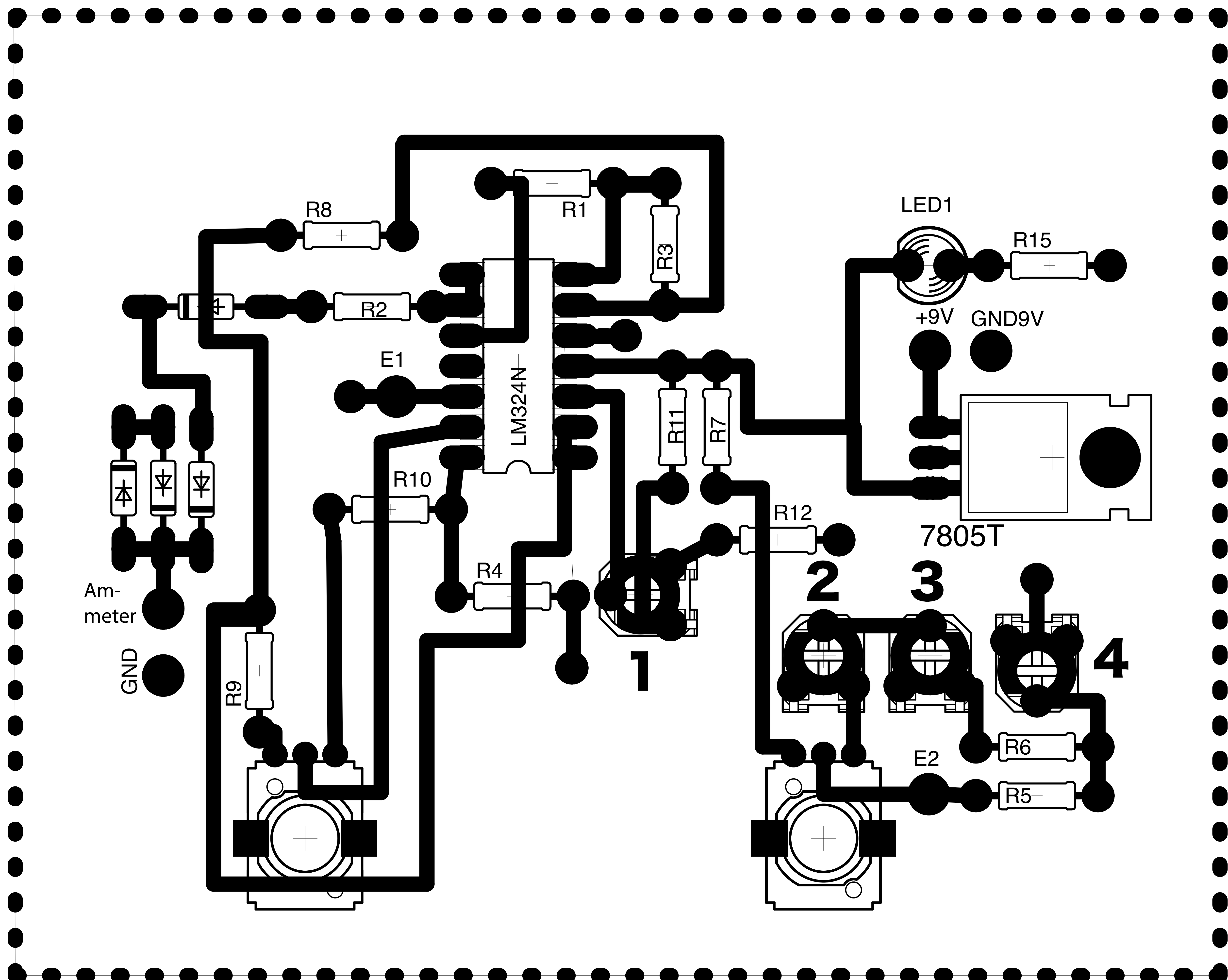
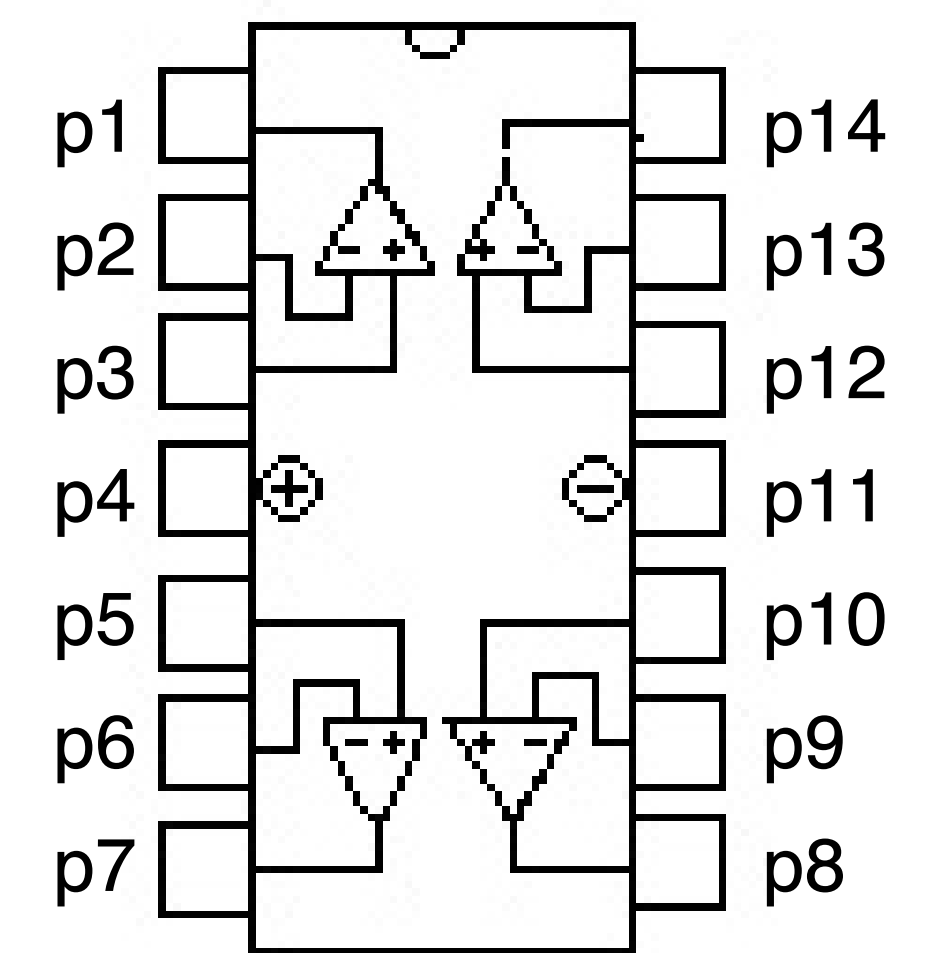

- 1: Pot left
- 2: Voltage transistor
- 3: Diodes
- 4: 4 x 22kOhm, R1, 4, 5, 8
- 5: 2 x 100kOhm, R3, 11
- 6: 2 x 1.5 Ohm, R9, 10
- 7: 5.6kOhm, R6
- 8: 10kohm, R7
- 9: 47kohm, R12
- 10: 1kohm, R2
- 11: 100ohm for LED R15
- 12: LED
- 13: Pot 100kohm
- 14: Wires

# The E-Meter & Auditing

The mechanics of the mind in clearing are only those mentioned in this section. To try it without a meter or without knowing meter well is, of course, beyond the observation ability of Homo Sapiens.

Only a meter registers these mechanics.  
Only processes blow these barriers to living.

— E-Meter Essentials 1961/2013  
L. Ron Hubbard

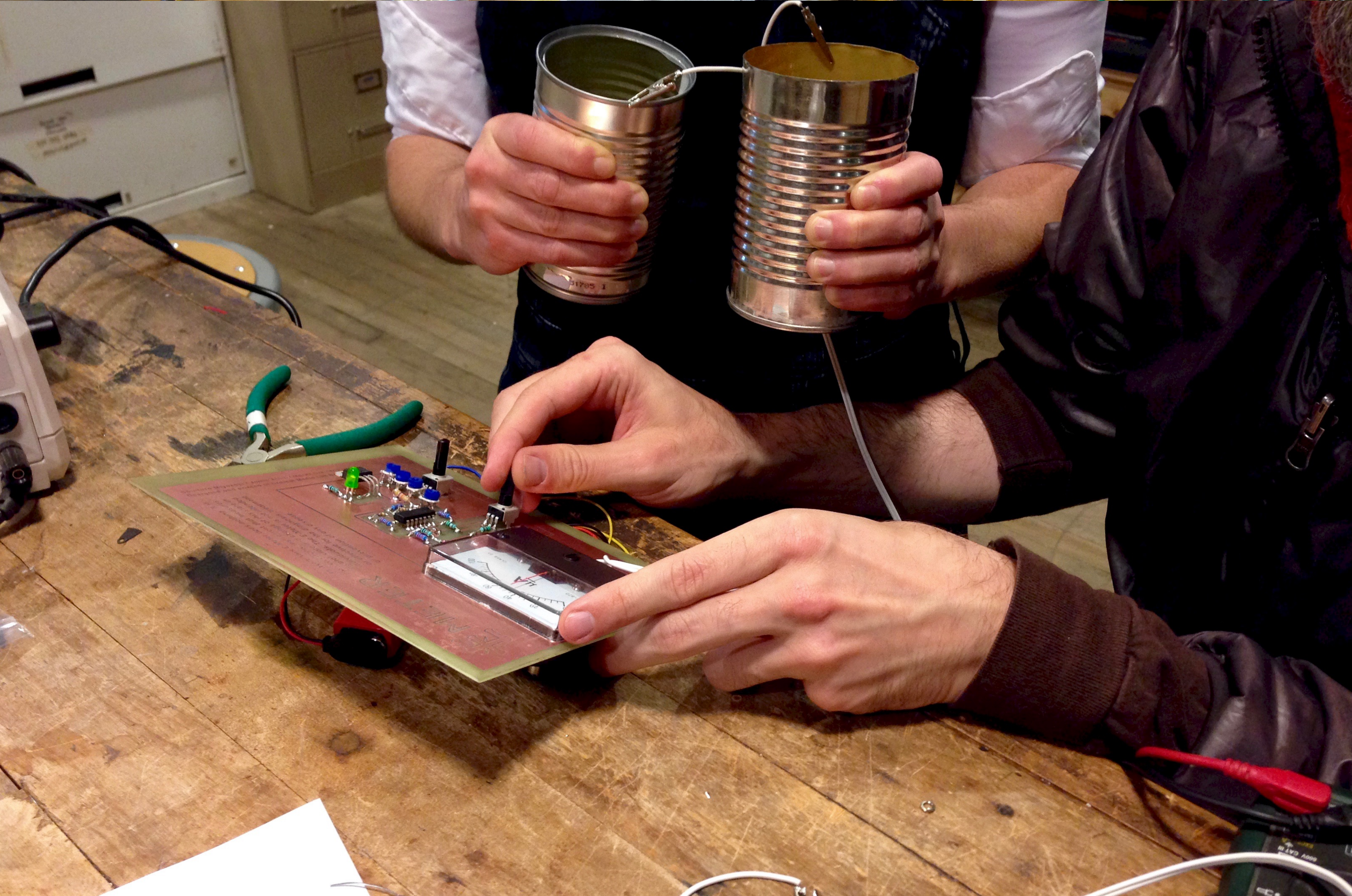

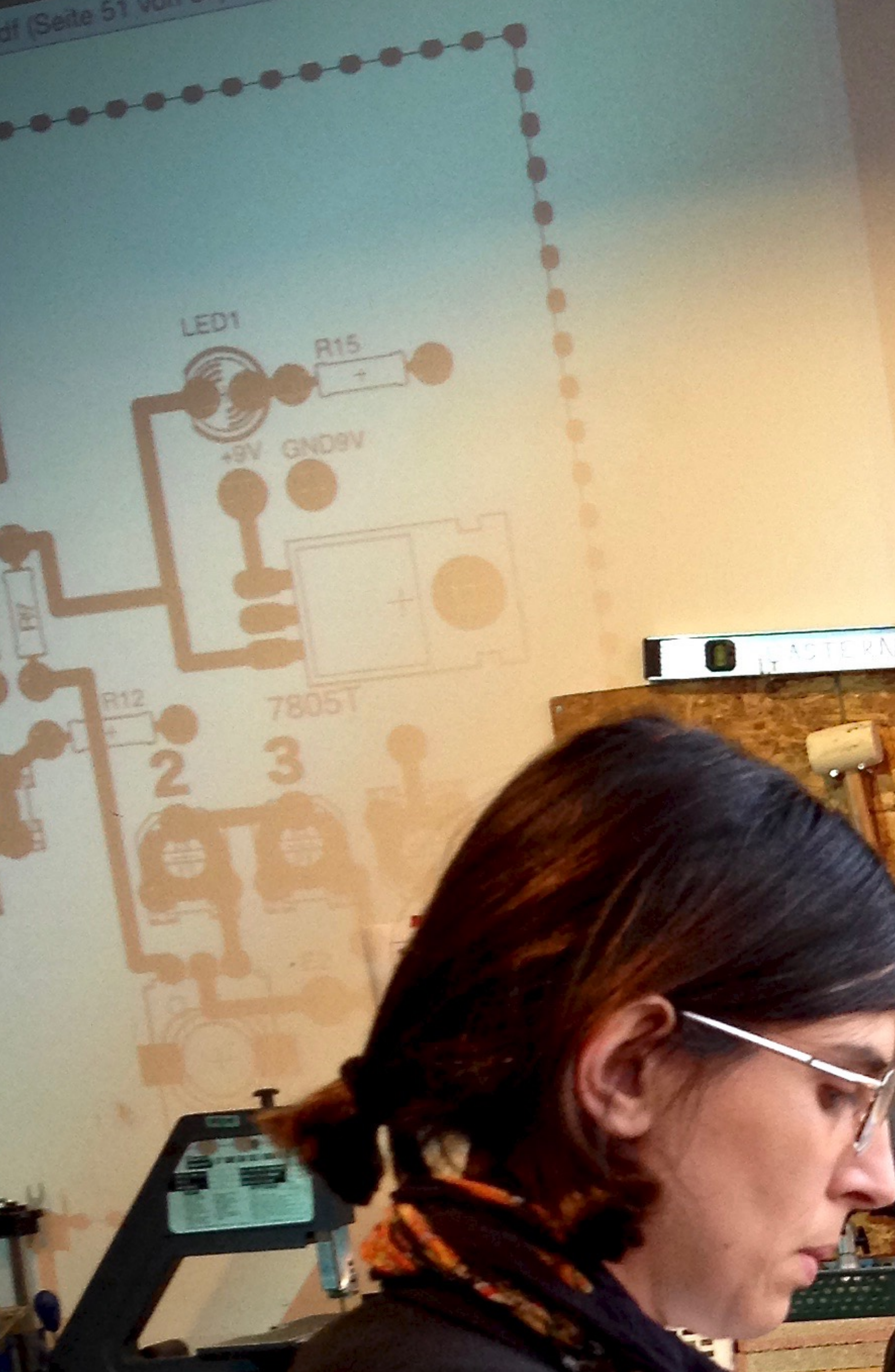

THE ESSENTIALS  
L. RON HUBBARD



The resistance of a dead female body is 5,000 ohms and of a dead male body, 12,500 ohms.

— LHR

## **THE NEEDLE (assorted needle behaviours)**

### **Stuck**

The pre-clear would not even register being pinched

### **No reaction (null)**

The question does not change the needle behaviour

### **Fall**

A falling needle makes a dip to the right as you face the meter. A fall is a read. It denotes that a disagreement with life on which the pre clear has greater or lesser reality has met the question asked. A fall is the most used and observed needle action. It means to the auditor, "I've found it" or "I've gotten a response in the bank." It denotes that a disagreement with life on which pre clear has greater or lesser reality has met the question asked.

### **Tick**

A tick is a small jerk of the needle that is really a tiny fall. Ticks are very important as they show a subject could be hot and could become a fall.

### **Stop**

A question that instantly stops a rising or a falling needle means we have struck something. Further exploration may develop it into a fall.

### **Theta Bop**

A theta bop is a small or wide steady dance of the needle. The needle goes up and down perhaps five or ten times a second. It goes up, sticks, falls, sticks, goes up, sticks, etc., always the same distance, like a slow tuning fork. A theta bop means "death," "leaving," "don't want to be here." It is caused by a yo-yo of the pre clear as a theta vibrating out and into the body or a position in the body. It's like the needle is jumping between two peaks across a narrow valley.

### **Rock Slam**

A rock slam is a crazy, irregular left-right slashing motion of the needle. It slams back and forth. A Rock Slam means a hidden eye intention on the subject or question under auditing discussion.

### **Dirty needle**

A dirty need is an erratic agitation of the needle which is ragged, jerky, ticking, not sweeping and tends to be persistent. It is not limited in size. It is caused by the auditor breaking the auditor's code and the pre clear withholding something he or she does not wish known.

### **Free needle (floating needle)**

You'll know one when you see one. They're really pretty startling. The needle just idles around the yawns at your questions on the subject. "Man it's really free."

### **Body reactions**

The deep breathing of a pre clear, a sigh a yawn, a sneeze, a stomach growl can, any one of them, make a needle react

Scientology is a model control system, a state in fact with its own courts, police, rewards and penalties. It is based on a tight ingroup like the CJA, Islam, the Mormons, etc. Inside are the Rights with the Truth. Outside are the Commies, the Infidels, the Unfaithful, the Suppressives. Rarely has this formula been expressed with such consummate effrontery, like you go into a store to buy a suit the clerk puts you in a Condition of Doubt, you work all night in the stock room and go around with a gray rag around your arm and petition the entire store to let you back in so you can buy something.

How does Hubbard do it? With the E-Meter of course. The E-Meter is among other things a reliable lie detector in expert hands. The CIA also uses lie detectors and runs Security Checks on all personnel. With this simple device any organization can become a God from whom no thought or action can be hidden.

The E-Meter is also a biofeedback device, and since it passes a small voltage through the brain and the repetitive commands of auditing direct attention to certain brain areas, it is a form of electric brain stimulation. This may account for the valid pictures and films that do sometimes occur in auditing.

Recently in America and for some time past in Russia telepathic experiments have been carried out on similar instruments. The Fall Read that characterizes fear, resistance, guilt, shame, can be produced from a distance by a sender who concentrates on persons or situations to which the receiver has a strong negative reaction. In short, auditing can be carried out telepathically from a distance so perhaps RON really audits you all.

— William Burroughs  
Alie's Smile, Naked Scientology 1978



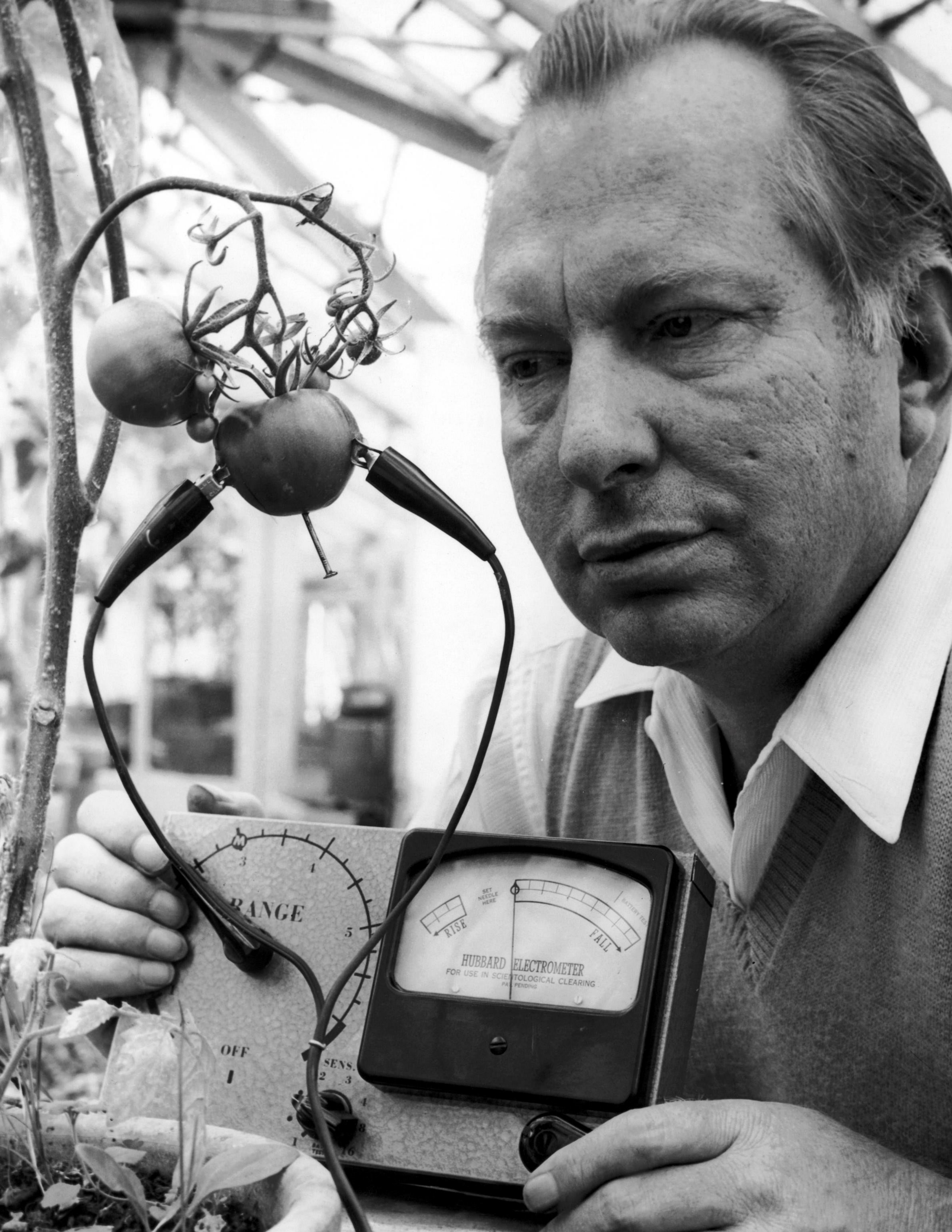

RANGE

OFF

SENS.

RISE

FALL

HUBBARD ELECTROMETER  
FOR USE IN SCIENTOLOGICAL CLEARING  
PAT. PENDING